

Swing door drive mechanism

ETS 73

Mounting and operating instructions

Original



Com. no. Pos. Construction year

Operator

Operating place

TABLE OF CONTENTS

1	GENERAL REMARKS	5
1.1	Target group.....	5
1.2	Where to keep these instructions	5
1.3	Adresses.....	5
1.4	Auxiliary tools and service performances	6
2	SAFETY	7
2.1	Appropriate use	7
2.2	Safety notices	7
2.3	Safety regulations.....	7
2.3.1	Principles.....	7
2.3.2	Service.....	9
2.3.3	Safety devices	9
2.3.4	Malfunctions	9
2.3.5	Accessories/Spare parts.....	9
3	PRODUCT DESCRIPTION.....	10
3.1	General remarks	10
3.2	Standard application	11
3.3	Inverse application.....	12
3.4	Automatic closing sequence control	12
3.5	Rating plate.....	13
3.6	Technical data.....	13
3.7	Application limits without safety elements according to EN 16005	14
3.8	Maximum wind-load capacity.....	15
4	MOUNTING	17
4.1	Preparation	17
4.2	Mounting versions.....	18
4.3	General.....	19
4.4	Normal rods pushing function / Lintel mounting.....	20
4.5	Sliding rods pulling function / Lintel mounting.....	23
4.6	Sliding rods pushing function / Lintel mounting	26
4.7	Sliding rods pushing function / Leaf mounting	29
4.8	Adjusting the pre-stressing of the closing spring	32
4.9	Setting the accelerating function (forceful closing)	34
4.9.1	Accelerating force.....	34
4.9.2	Forceful closing range	35
5	ELECTRICAL CONNECTIONS	36
5.1	Power supply	36
5.2	Cable layout.....	38
5.2.1	Lintel mounting	38
5.2.2	Leaf mounting.....	38
5.2.3	Strain relief	39
5.3	External elements.....	39
5.4	Motorized lock.....	40
5.4.1	Motorised lock with direct connection to motor coil	40
5.4.2	Motorized lock with own evaluation control	41
5.4.3	Motorized lock with separate evaluation control/power pack	42

6	COMMISSIONING	43
6.1	Inverse application	45
6.2	Closing sequence control	46
6.3	Interlock operation	49
6.4	Adhesive labels	50
6.4.1	Service sticker	50
6.4.2	Diagram sticker	50
6.5	Mount the drive unit covering	51
7	CONTROL	52
7.1	Main switch	52
7.2	Program selector	52
7.3	Operating modes	53
7.4	Adjustings	54
7.4.1	Motional parameters (PARAMETER)	54
7.4.2	Configuration (CONFIG)	55
7.4.3	Installations with multiple door leaves (DOUBLE DOOR)	56
7.4.4	Menu navigation	57
8	SERVICE	61
8.1	Service for pedestrian doors	62
8.2	Fundamental checking	63
9	TROUBLESHOOTING	64
9.1	Malfunction with error-no.	64
9.1.1	Drive mechanism	64
9.1.2	Operating	65
9.1.3	Safety elements	65
9.1.4	Feeding	65
9.1.5	System	66
9.1.6	Options	66
9.1.7	Closing sequence / Interlock function	66
9.2	Malfunction without error-no.	67
9.3	Software update via USB	68
9.3.1	Preparation	68
9.3.2	Procedure	69
9.3.3	LED display on the control	69
9.3.4	Possible errors	69

10	SHUT-DOWN.....	70
11	DISPOSAL OF THE INSTALLATION.....	71
12	SPARE PARTS	72
13	OPTIONS.....	73
13.1	D-BEDIX	73
13.1.1	Keys.....	73
13.1.2	Symbols.....	73
13.1.3	Operating modes	74
13.1.4	Display of the door position	74
13.1.5	Menu level	75
13.1.6	Setting examples	76
13.1.7	Error display	77
13.2	KOMBI-D-BEDIX	78
13.3	Open position stop piece integrated in the drive unit.....	79
13.4	Connection plate for wooden door leaf (normal rods).....	79
13.5	Mounting plate	80
13.6	Mounting plate ETS 73 Mod	80
13.7	Continuous covering.....	81
13.8	Optional PCBs	82
13.8.1	Relay PCB.....	82
13.8.2	Radio PCB.....	83
13.9	LZR-FLATSCAN	84
14	APPENDIX.....	85
	Wiring diagram.....	E4-0141-713_ECO
	Wiring diagram Relay PCB	E4-0141-715_ECO
	Wiring diagram motorised locks.....	E4-0142-180_ECO

1 GENERAL REMARKS

The present instructions contains all instructions for mounting, commissioning, operation, service (maintenance/checking) as well as troubleshooting. It is the basis guaranteeing a faultless and safe operation of the installation and must be completely read and understood before starting the work.

The following basic documents are associated with this installation:

- **Mounting and operating instructions** **0548-990/52** onto the installation
- Operator manual 0548-991/42 by the operator
- Control booklet 0548-991/52 onto the installation

1.1 Target group

All the work described in the present instructions must only be carried out by experts!

Experts are persons who, based on their professional training and experience, have sufficient knowledge in the field of powered windows, doors and gates. They are sufficiently familiar with the relevant federal regulations for work protection and accident prevention, with the guidelines and generally recognized rules applicable for this field of technology which enables them to evaluate if powered windows, doors and gates can be safely operated.

Only the trained experts of the manufacturer or the supplier are counted among these persons.

1.2 Where to keep these instructions

The present instructions have to be kept close to the installation, together with the control booklet!

1.3 Adresses

Distribution agent/
After-sales service



Distribution

ECO Schulte GmbH & Co. KG
Iserlohner Landstrasse 89
D-58706 Menden
Tel. +49 23 73 / 92 76-0
Fax +49 23 73 / 92 76-40
www.eco-schulte.de

1.4 Auxiliary tools and service performances

The auxiliary tools and service performances listed hereafter are available, depending on the respective situation and authorization (please ask your distribution agent):

- Company portrait
- Homepage
- News
- Info-News via E-mail
- Product brochures
- Product presentation (PowerPoint)
- Submission texts
- Reference list
- Test/homologation certificates
- CAD data
- Application sheets
- Plans of installations and cutouts
- Training courses
- Spare parts
- Maintenance contracts
- Around-the-clock service (not available in all the countries)

2 SAFETY

2.1 Appropriate use

The swing door drive mechanism ETS 73 has been exclusively designed for operating swing doors. Any other use beyond these application limits is deemed inappropriate and inadmissible! In the event of an inappropriate use of this system, the safety of the user may be jeopardized and/or the installation be damaged. The manufacturer declines all responsibility for these injuries/damages!

2.2 Safety notices

The present instructions uses the following symbols and notes in order to point out certain residual dangers:



Warning:
Involving danger to life and limb.



Attention:
A situation where material could be damaged or the function impaired.



Note:
Hints which facilitate the work.

2.3 Safety regulations

2.3.1 Principles

- According to standard EN 16005/DIN 18650 describing the safety-related requirements for automatic door systems, a risk evaluation is to be carried out (in consideration of the groups of door users and the local situation). This is the basis for the choice of the different protecting measures. The risk evaluation has to be carried out already during the planning stage to guarantee that the automatic door system can be safely installed and operated.
- When configuring the installation, it is essential to make sure that the locally applicable regulations with regard to the closing edges are complied with, in order to avoid crushing and shearing points. It is particularly important to make sure that the door leaves do not have any sharp edges. The secondary closing edges must be designed by customers in such a fashion as to eliminate any dangerous crushing and shearing points.

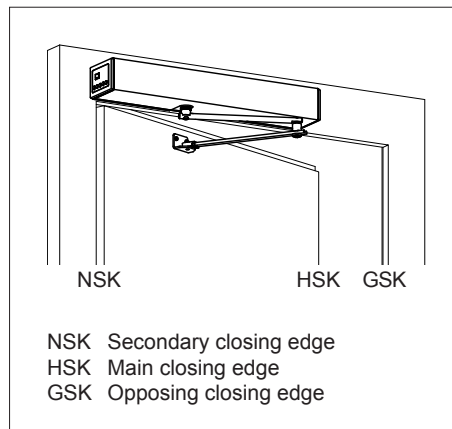

- In order not to create any dangerous squeezing and shearing points, no structural modification must be made within the door surroundings, without prior authorization from ECO Schulte GmbH & Co. KG. Furthermore, it is important that no objects (such as furniture, pallets, etc.) be placed in the vicinity of the door.
- The door leaves and their fillings must be manufactured according to the applicable standards (e.g. EN 16005). For the door leaf fillings, brake-proof material respectively safety glass shall be used. Transparent door leaves (or their surfaces) must be clearly recognizable, e.g. by means of a permanent marking or dyed materials.
- The application limits must be observed.
- The choice of fastening elements depends on the construction base.
- Door sills or other protruding elements of the door system are to be identified by warning stickers or another appropriate marking means.
- In its assembled state, the installation must answer all the safety requirements specified by the machinery directive.
- The swing door drive mechanism ETS 73 may only be installed and operated in dry rooms. If this condition cannot be fulfilled, the customer must provide sufficient protection from moisture.
- The swing door drive mechanism ETS 73 must not be mounted within locations presenting explosion hazards. The presence of flammable gases or smoke represents a considerable safety hazard.
- All further interventions on and modifications of the installation that are not described in the present instructions are forbidden!
- Wrapping materials (such as plastic foil, polystyrene foam, strings, ...) represent a source of danger for children and must therefore be kept out of reach of the latter.
- The installation has been calculated, designed and manufactured on the basis of the latest state-of-the-art technology and the generally recognized safety-relevant rules and regulations. It may only be operated if it is in perfect condition, taking into account the specifications of the present instructions. Any use beyond the defined application limits is inadmissible!
- The installation is to be operated and maintained in such condition that the safety is guaranteed at all times. An integral part of this condition is the appropriate use, the compliance with the operating conditions prescribed by the manufacturer, as well as the regular service (maintenance/checking).
- The installation's conformity with the machinery directive must be confirmed.

2.3.2 Service

In order to guarantee the safety of the users at all times, the installation must be checked with regard to its safe condition before the first commissioning and during normal operation, **at least once a year**, by a expert. The correct maintenance/checking must be confirmed by entering the date and signature into the control booklet.

2.3.3 Safety devices

It is inadmissible to bypass, shunt or disable the safety devices. Any defective safety devices may not be disconnected in order to be able to continue the operation of the installation.

2.3.4 Malfunctions

If any malfunctions occur which might be detrimental to the safety of the users, the installation must be immediately taken out of operation. It may only be taken back into operation after the malfunction has been repaired and all danger eliminated.

2.3.5 Accessories/Spare parts

A safe and reliable function of the installation can only be guaranteed if it is operated with the original ECO Schulte GmbH & Co. KG accessories/spare parts. ECO Schulte GmbH & Co. KG declines all responsibility for damages resulting from unauthorized modifications of the installation or from the use of foreign accessories/spare parts.

3 PRODUCT DESCRIPTION

3.1 General remarks

The swing door drive mechanism ETS 73 opens and closes the door leaf via a rod assembly (is not shown in the illustration).

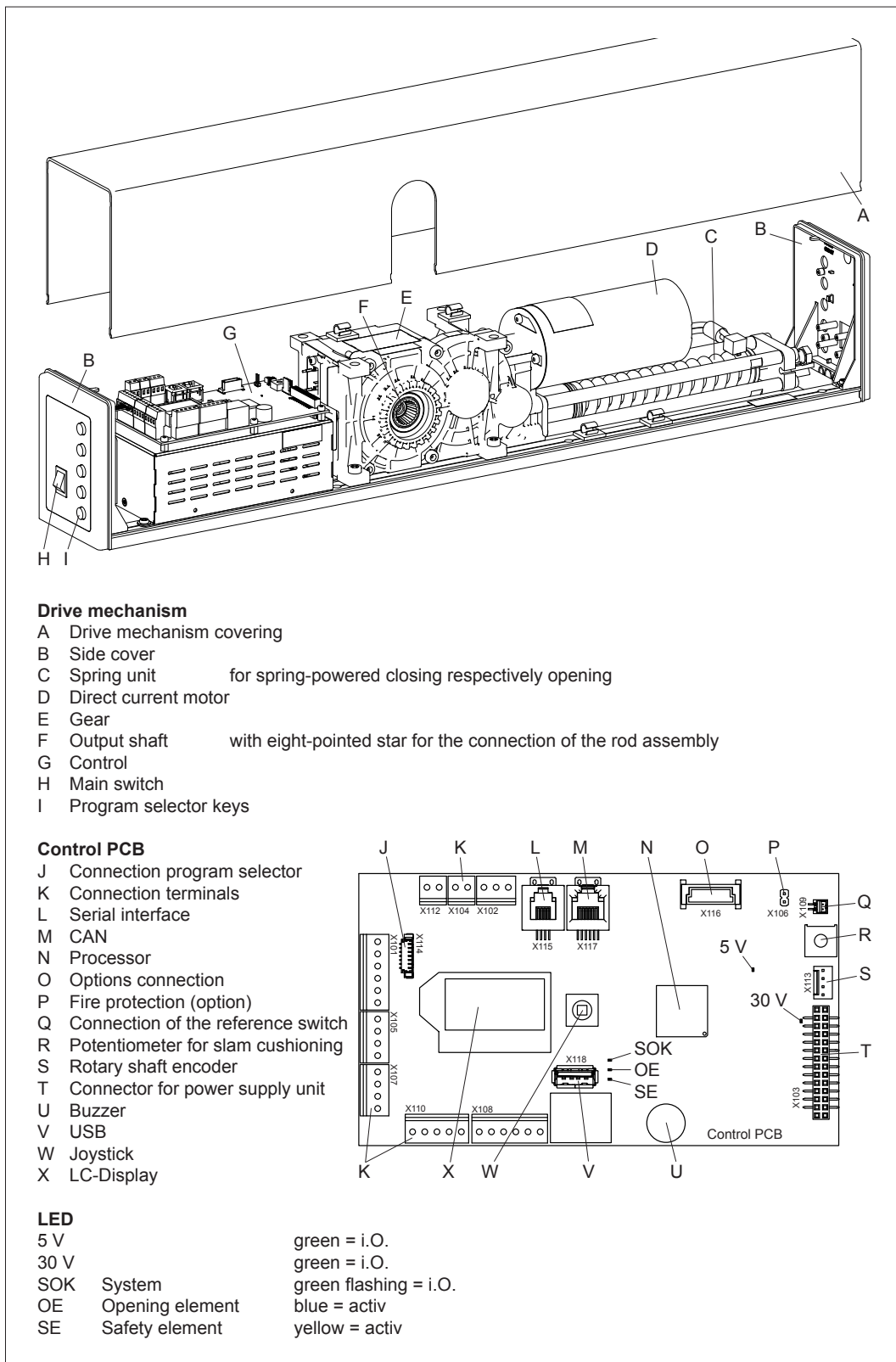

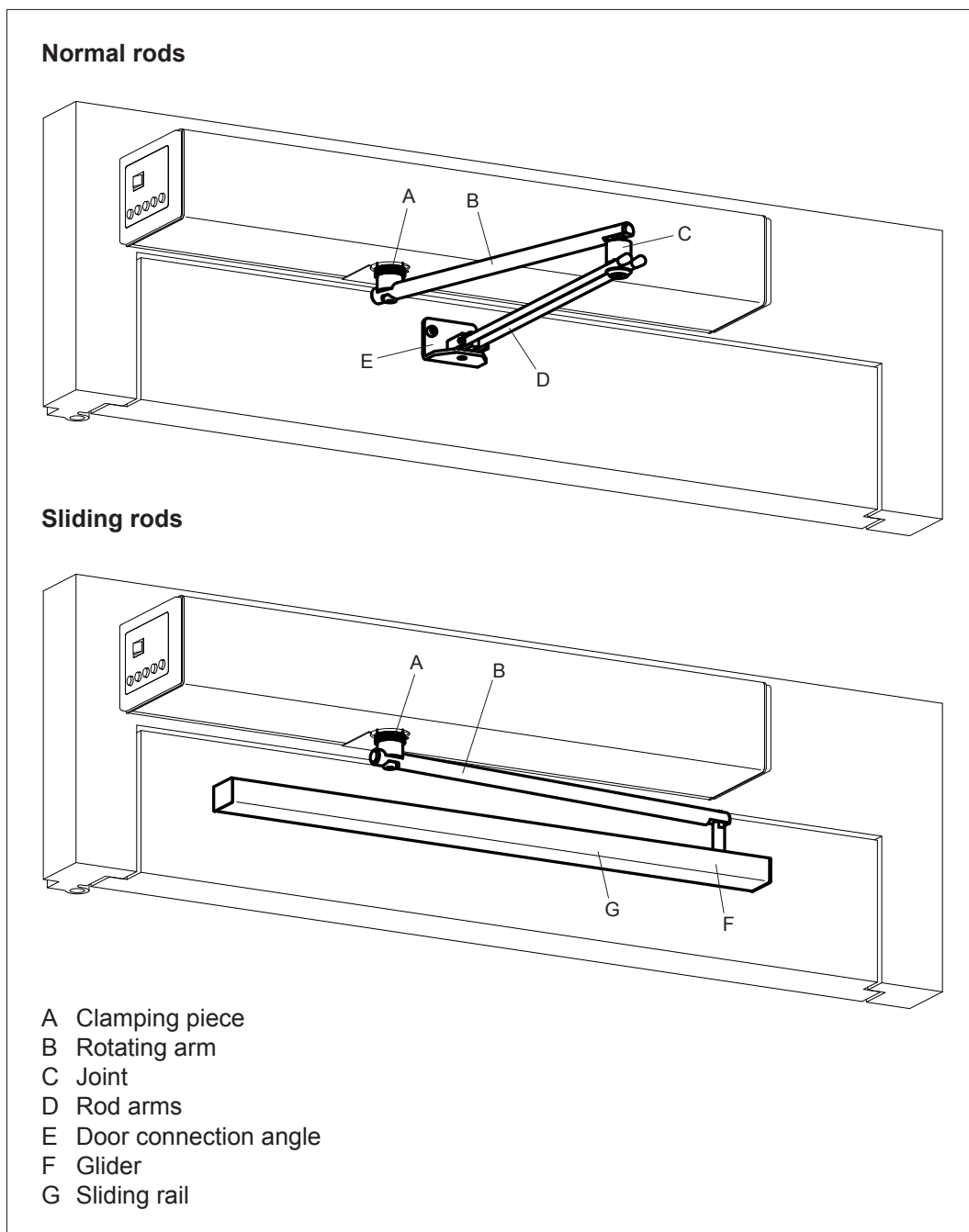

3.2 Standard application

During normal operation, the opening and closing movements of the door leaf are motorized. The automatically opening is performed via opening elements. The automatically closing starts as soon as the programmed hold-open time has expired.

Function in the event of a mains failure

The door leaf is closed from any position by means of spring power. The motor attenuation ensures a controlled closing.

3.3 Inverse application

The swing door drive unit ETS 73 is also appropriate for inversed operation. This particular function can be separately programmed for each drive unit. In the event of a power failure, the inverse application ensures that the door leaf is reliably opened.

During normal operation, the opening and closing movements of the door leaf are motorized. The automatically opening is performed via opening elements. The automatically closing starts as soon as the programmed hold-open time has expired.

Function in the event of a mains failure or emergency open

The door leaf is opened from any position by means of spring power (unless it has not been locked). The motor attenuation ensures a controlled opening. An emergency power supply system is therefore not necessary.

3.4 Automatic closing sequence control

For bi-parting installations, two separate ETS 73 swing door drive mechanisms are used, which are connected via the CAN bus system.

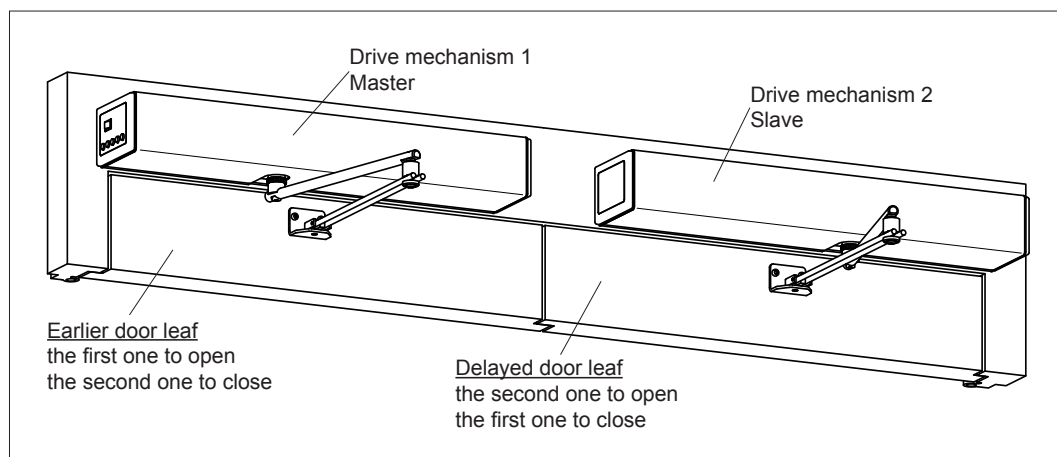

3.5 Rating plate

The rating plate (including TÜV and EC identification) can be found on the direct current motor (below the drive unit covering).

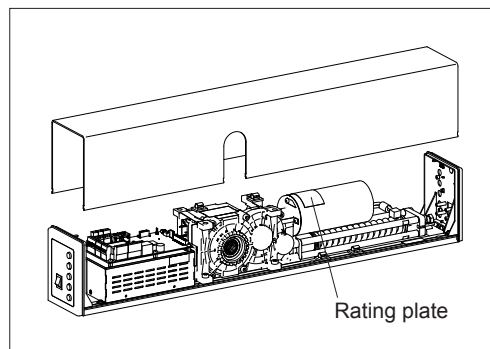

3.6 Technical data

Drive mechanism	Standard
Power transmission	Normal rods Sliding rods
Dimensions drive mechanism	Height 95 mm Width 690 mm Depth 120 mm
Weight drive mechanism	10,5 kg
Ambient temperature	-15...+50 °C
May only be used in dry rooms	max. relative humidity 85 %
Protection type	IP 40 (IP 42*)
Operating voltage	230 VAC (+10/-15 %), 50 Hz, 10/13 A
Power consumption drive mechanism	max. 560 W
Motor power rating	100 W
Power supply external consumer	24 VDC (±10 %), 2 A
Torque output shaft	max. 80 Nm
Distance door hinge - Output shaft	mounting against lintel 280 mm leaf mounting 380 mm
Lintel depth	normal rods max. 250 mm sliding rods +150/-30 mm
Door opening angle	max. 105°
Weight of door leaf	max. 250 kg
Width of door leaf	EN 3...7 (851...1'600 mm) see chapter "Application limits"
Opening speed	max. 40°/s
Closing speed	max. 40°/s
Range of the accelerating function (forceful closing) (without mains power)	5...15° stepless adjustable (mechanical)
Motor damping (without mains power) within the range of the accelerating function (forceful closing)	stepless adjustable (adjusting trimmer)
Hold-open time	0...60 s
Hold-open time Night	0...180 s

* For obtaining the protection type IP 42, the drive mechanism covering must be sealed all around!

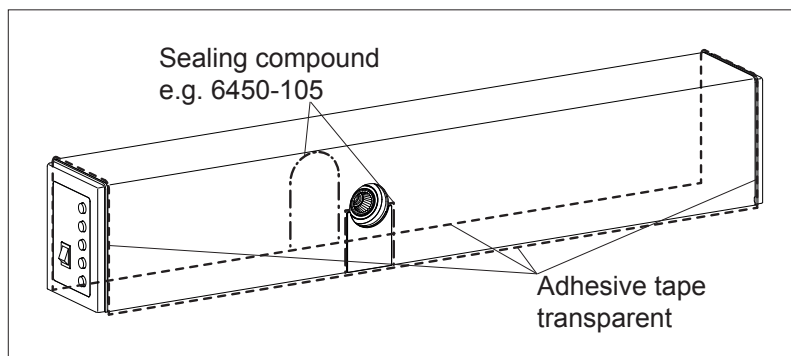

3.7 Application limits without safety elements according to EN 16005



Warning:

In the event of swing doors installed in a non publicly accessible areas, without installation of safety elements that monitor the door leaf movement, the setting values specified hereafter for the **opening speed V_o** and the **closing speed V_c** must not be exceeded.

Normal rods pushing function (lintel mounting)

Leaf width \ Leaf weight		Leaf weight					
		0...50 kg	51...90 kg	91...130 kg	131...170 kg	171...210 kg	211...250 kg
EN 3	851...950 mm	6	5	3	2	2	1
EN 4	951...1'100 mm	5	4	4	3	3	2
EN 5	1'101...1'250 mm	5	5	4	3	3	2
EN 6	1'251...1'400 mm	5	4	3	3	3	2
EN 7	1'401...1'600 mm	2	2	2	2	1	1

Sliding rods pushing function (lintel mounting)

Leaf width \ Leaf weight		Leaf weight					
		0...50 kg	51...90 kg	91...130 kg	131...170 kg	171...210 kg	211...250 kg
EN 3	851...950 mm	4	4	3	1	1	-
EN 4	951...1'100 mm	4	2	2	1	1	1
EN 5	1'101...1'250 mm	3	3	2	1	1	1
EN 6	1'251...1'400 mm	3	3	3	1	1	1
EN 7	1'401...1'600 mm	2	2	2	1	1	-

Sliding rods pulling function (lintel mounting)

Leaf width \ Leaf weight		Leaf weight					
		0...50 kg	51...90 kg	91...130 kg	131...170 kg	171...210 kg	211...250 kg
EN 3	851...950 mm	5	4	4	2	1	1
EN 4	951...1'100 mm	4	3	3	2	1	1
EN 5	1'101...1'250 mm	4	3	2	1	1	1
EN 6	1'251...1'400 mm	3	3	2	1	1	-
EN 7	1'401...1'600 mm	3	2	2	1	1	-

Sliding rods pushing function (leaf mounting)

Leaf width \ Leaf weight		Leaf weight					
		0...50 kg	51...90 kg	91...130 kg	131...170 kg	171...210 kg	211...250 kg
EN 3	851...950 mm	4	3	2	2	1	1
EN 4	951...1'100 mm	4	3	1	1	1	-
EN 5	1'101...1'250 mm	3	2	1	1	1	-
EN 6	1'251...1'400 mm	2	2	1	1	-	-
EN 7	1'401...1'600 mm	2	1	1	1	-	-

3.8 Maximum wind-load capacity

Normal rods pushing function (lintel mounting)

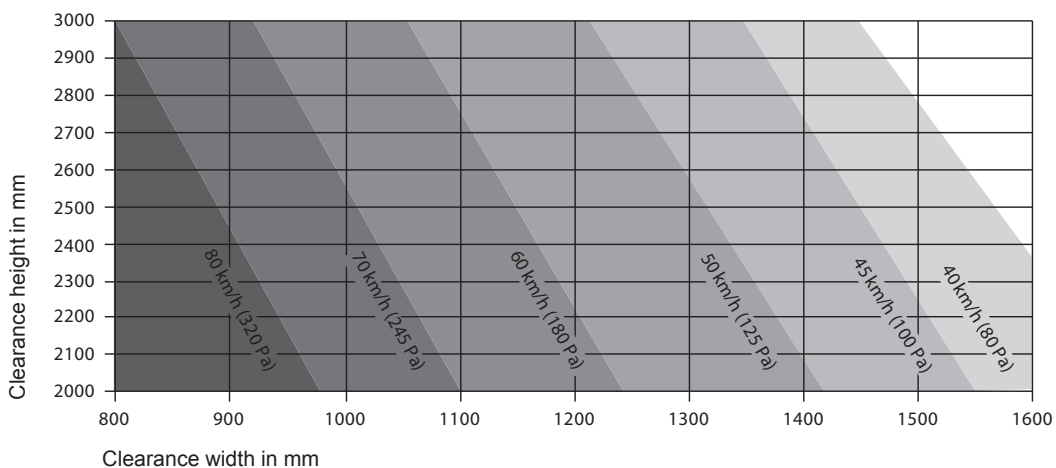

Sliding rods pushing function (lintel mounting)

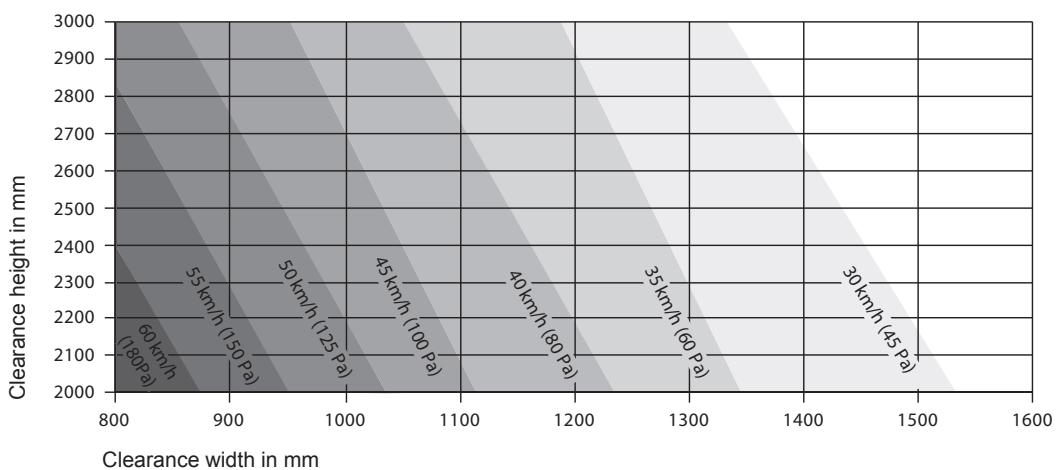

Sliding rods pulling function (lintel mounting)

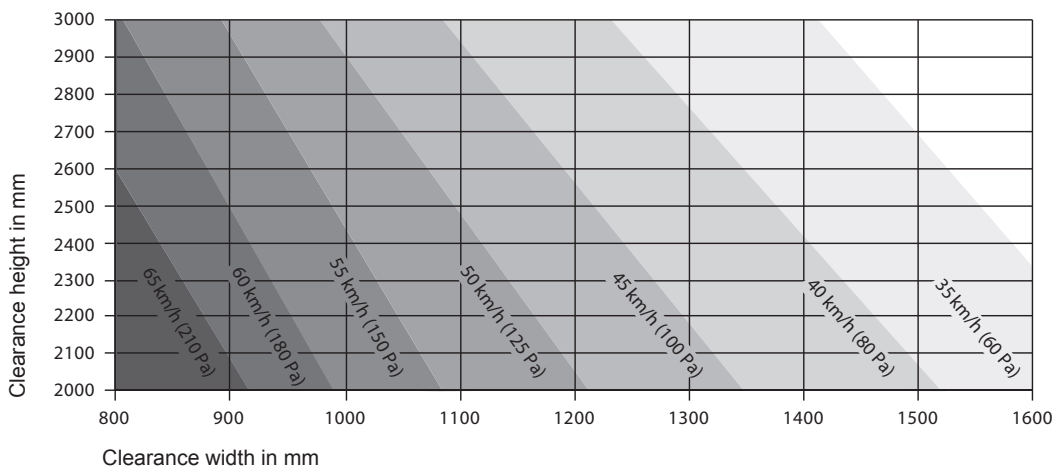

Sliding rods pushing function (leaf mounting)

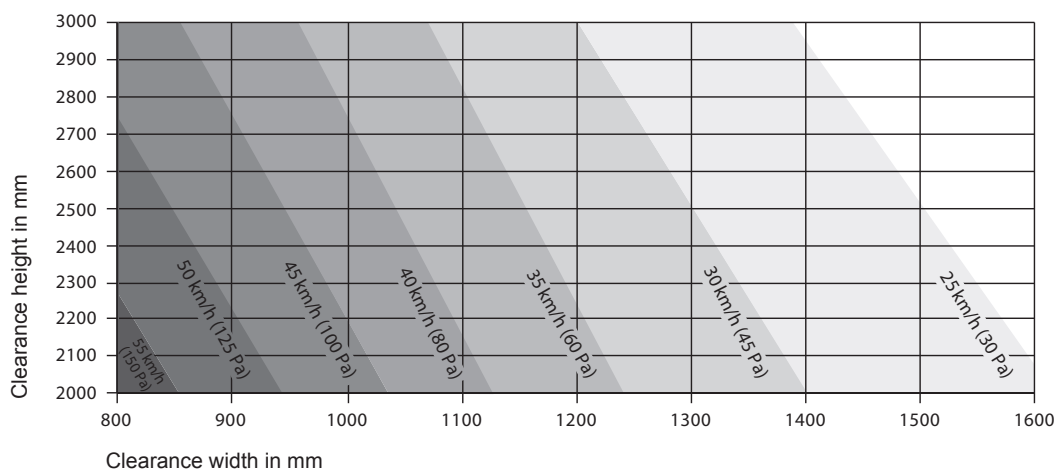

4 MOUNTING

4.1 Preparation



Attention:

Standard application

It is recommended that a door leaf stop piece be mounted by the customer.

Inverse application

It is imperative for the customer to install a door leaf stop piece!

This stop piece prevents the door leaf from being damaged in the manual operating mode. As an option, an open position stop piece can be integrated into the drive unit itself.

1. Check the free running movement of the door leaf.
Should it fail to move smoothly and silently, or if it is out of balance (i. e. it opens or closes by itself), these problems must be eliminated first!



Attention:

The motor connector plug must be re-connected in the control unit, according to the respective mounting version (Y = standard ⇔ see chapter 4.2 Mounting versions). This in order to ensure the cushioning function.

2. Loosen the two screws (A).
3. Pull the control (B) out from under the gearbox housing (C).
4. Re-connect the motor connector plug (D).
5. Remount the control unit (B).

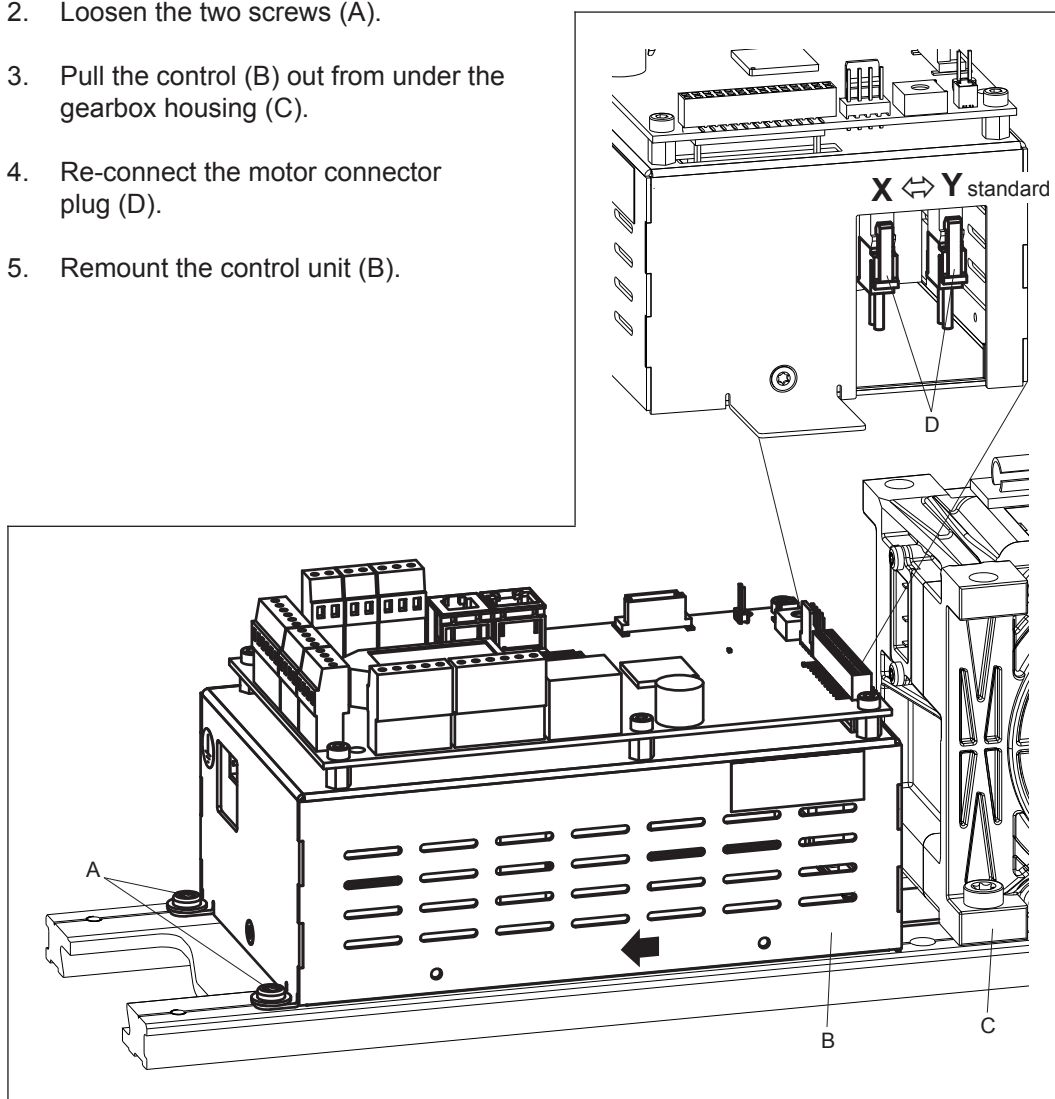

4.2 Mounting versions

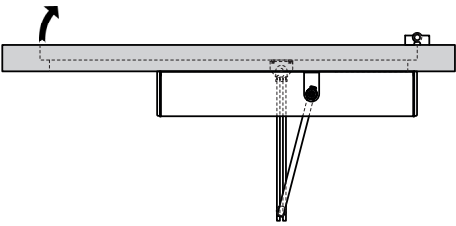
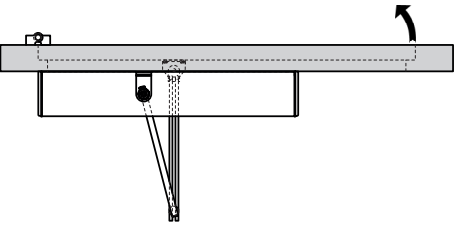
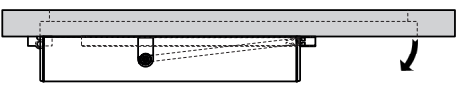
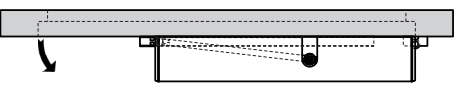
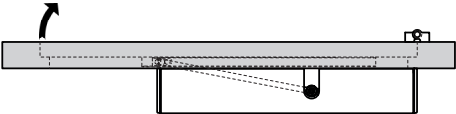
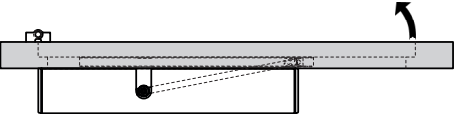
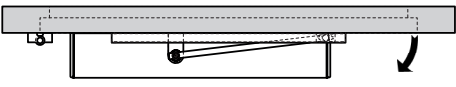
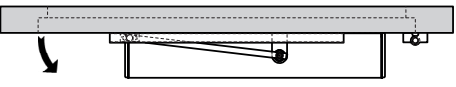
DIN left	DIN right
 <p>Normal rods 0548-104 pushing function 0548-104/01 KTL push. funct. Lintel mounting see chapter 4.4 Lintel depth 0...250 mm Drive mechanism 0548-030 alu / 0548-031 inox Motor connector plug Standard Y, Inverse X see chapter 4.1</p>	 <p>Normal rods 0548-104 pushing function 0548-104/01 KTL push. funct. Lintel mounting see chapter 4.4 Lintel depth 0...250 mm Drive mechanism 0548-030 alu / 0548-031 inox Motor connector plug Standard Y, Inverse X see chapter 4.1</p>
 <p>Sliding rods 0548-134 (620 mm) pulling 0548-105/02 (830 mm) Lintel mounting see chapter 4.5 Lintel depth -30/+80 mm (+200 mm) Drive mechanism 0548-030 alu / 0548-031 inox Motor connector plug Standard X, Inverse Y see chapter 4.1</p>	 <p>Sliding rods 0548-134 (620 mm) pulling 0548-105/02 (830 mm) Lintel mounting see chapter 4.5 Lintel depth -30/+80 mm (+200 mm) Drive mechanism 0548-030 alu / 0548-031 inox Motor connector plug Standard X, Inverse Y see chapter 4.1</p>
 <p>Sliding rods 0548-134 (620 mm) pushing 0548-105/02 (830 mm) Lintel mounting see chapter 4.6 Lintel depth -30/+70 mm (+200 mm) Drive mechanism 0548-030 alu / 0548-031 inox Motor connector plug Standard Y, Inverse X see chapter 4.1</p>	 <p>Sliding rods 0548-134 (620 mm) pushing 0548-105/02 (830 mm) Lintel mounting see chapter 4.6 Lintel depth -30/+70 mm (+200 mm) Drive mechanism 0548-030 alu / 0548-031 inox Motor connector plug Standard Y, Inverse X see chapter 4.1</p>
 <p>Sliding rods 0548-105/02 pushing function incl. sliding rail 830 mm Leaf mounting see chapter 4.7 Lintel depth -30/+200 mm Drive mechanism 0548-030 alu / 0548-031 inox Motor connector plug Standard Y, Inverse X see chapter 4.1</p>	 <p>Sliding rods 0548-105/02 pushing function incl. sliding rail 830 mm Leaf mounting see chapter 4.7 Lintel depth -30/+200 mm Drive mechanism 0548-030 alu / 0548-031 inox Motor connector plug Standard Y, Inverse X see chapter 4.1</p>

4.3 General



Warning:

The fastening bases must provide sufficient solidity. If necessary they have to be reinforced by the appropriate means.



Attention:

The maximum admissible undulation of the fastening base is 1 mm. The drive unit must be fastened without torsion and perpendicularly, using all the six fixing holes!



Warning:

Tighten all the six M6 fixing screws (A) with a torque of 10 Nm!

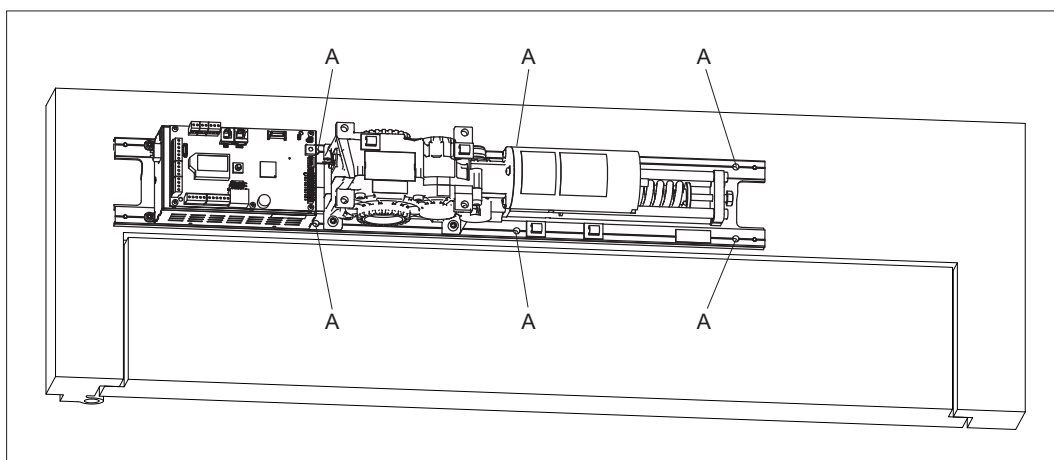

Note:

Depending on the assembly situation of the drive unit, it may be advisable to install the program selector on the opposite side (in order to guarantee an optimal operating facility). Should this be required, the work must be carried out according to chapter "Electrical connections".



Note:

In cases where it is planned to integrate an open position stop piece into the drive unit (option), this stop piece must be mounted prior to the rod assembly (see instructions for option).



Note:

In case FLATSCANS are planned, they must be mounted according to chapter 13.9.

4.4 Normal rods pushing function / Lintel mounting

Material:

1	Drive mechanism	0548-030	Covering aluminium
	Drive mechanism	0548-031	Covering inox
	incl. fixing set	0548-107	
1	Normal rods	0548-104	
	Normal rods KTL	0548-104/01	

Procedure:

1. Mark out and drill the fastening holes on the lintel and the door leaf.

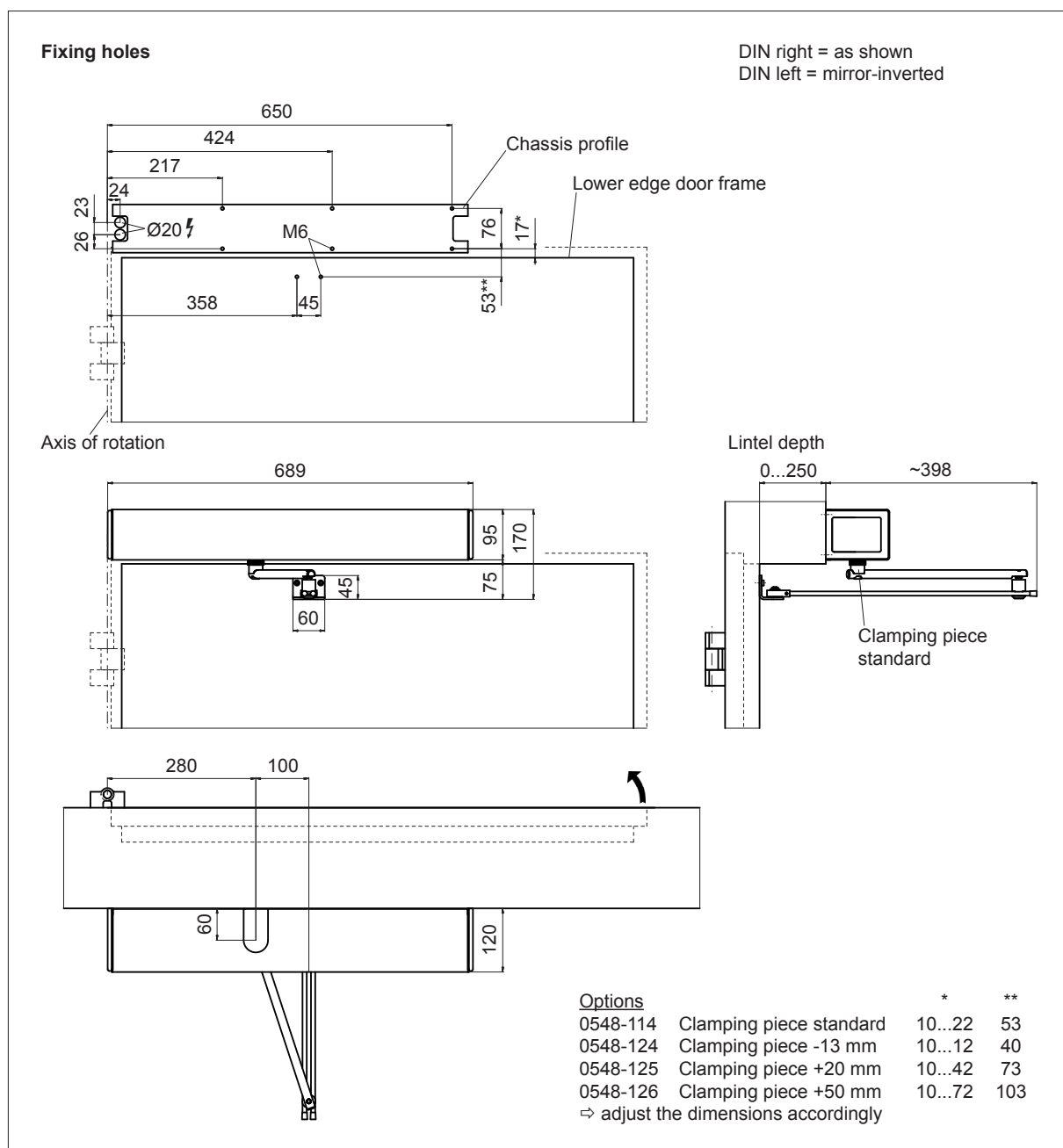

Drive mechanism standard

2. Mount the drive mechanism.
3. Close the door leaf.
4. Separate the rotating arm (D) from the rod arm (B) by dismounting the ball and socket joint (E).
5. Fasten the rod arm (B) by means of the door connection angle (A) onto the door leaf.
6. Position the lever arm (D) including the clamping piece (C) perpendicularly with regard to the door leaf and screw the lever arm (D) down in this position.
7. Slightly loosen the screw (F) of the rod arm (B) and snap in the ball and socket joint (E) which connects the rotating arm with the rod arm.
8. Prestress the rotating arm (D) until the rod arm (B) forms a right angle with the door leaf. Fasten the rod arm (B) by means of the screw (F).
9. Tighten all the screws.

⇒ forward to chapter 4.8

Inverse application

2. If existing:
Sub-assemble the drive-internal open position stop piece, integrated in the drive mechanism (see Option instructions 0548-992/02).
3. Mount the drive mechanism.
4. Separate the rotating arm (D) from the rod arm (B) by dismounting the ball and socket joint (E).
5. Fasten the rod arm (B) by means of the door connection angle (A) onto the door leaf.
6. Completely open the door leaf (max. 110°).
7. Position the lever arm (D) including the clamping piece (C) perpendicularly with regard to the door lintel (direction open position) and screw the lever arm (D) down in this position.
8. Slightly loosen the screw (F) of the rod arm (B) and snap in the ball and socket joint (E) which connects the rotating arm with the rod arm.
9. Close the door leaf.
10. Position the rod arm (B) perpendicularly with regard to the door leaf. Fasten the rod arm (B) by means of the screw (F).
11. Tighten all the screws.

⇒ forward to page 21



Attention: Check the motional sequence of the door leaf: The rods must not touch. If the rod arm (B) juts out too much, it can be shortened if necessary.

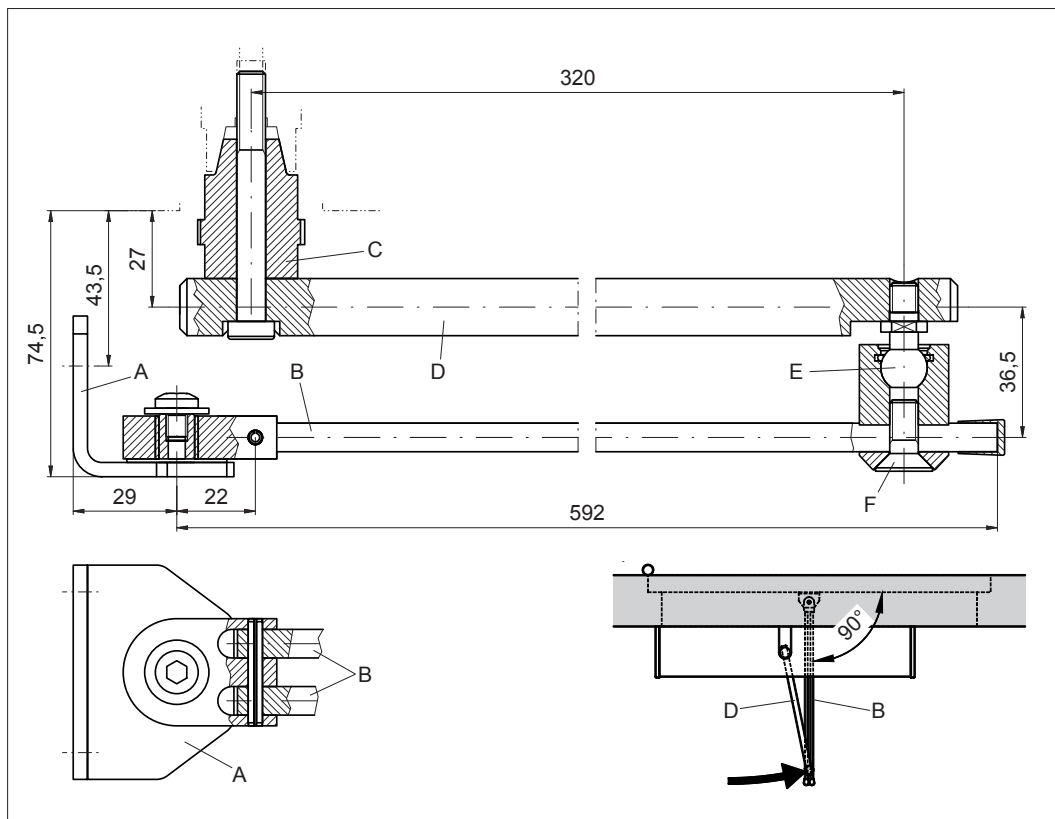

Inverse application

1. Let the door leaf be opened by spring power
2. Using a screwdriver, carefully prize the service cover (C) out of the gearbox housing.
3. By means of a socket wrench 1,5 mm, slightly loosen the locking screw (B) and leave the socket wrench inserted in the locking screw (B).
4. Close the door leaf.
5. Carefully turn the cam disk (A) to the left or to the right until the locking screw (B) is located at the highest point and the socket wrench is in a vertical/perpendicular position. Tighten the locking screw (B).
6. Snap the service cover (C) into the gearbox housing.
7. Mount the open position stop piece approx. 5° before the door leaf reaches the maximum open position.
If existing:
Setting of the open-position stop piece, integrated in the drive mechanism (see Option instructions 0548-992/02).

⇒ forward to chapter 4.8

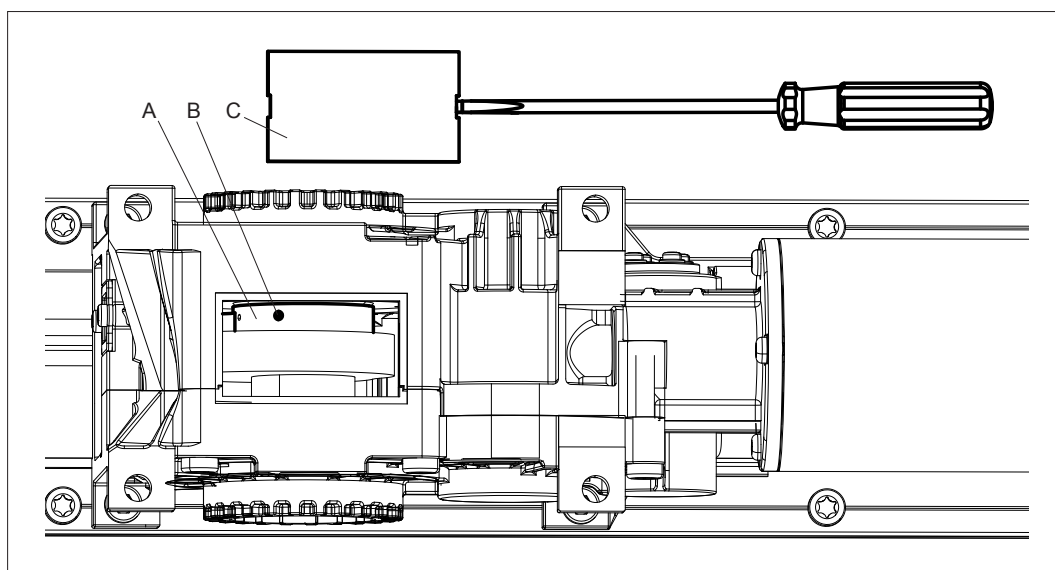

4.5 Sliding rods pulling function / Lintel mounting

Material:

1	Drive mechanism	0548-030	Covering aluminium
	Drive mechanism	0548-031	Covering inox
	incl. fixing set	0548-107	
1	Sliding rods	0548-134	620 mm incl. sliding bolts 14/38 mm
	Sliding rods	0548-105/02	830 mm incl. sliding bolts 14/38 mm

Procedure:

1. Mark out and drill the fastening holes on the lintel and the door leaf.



Note:

The illustration shows a 38 mm sliding bolt. Depending on the situation, this bolt can be replaced by the version 14 mm. This will change the respective dimensions by minus 24 mm.

Fixing holes

DIN left = as shown
 DIN right = mirror-inverted

Lintel depth (mm)	Min. width door leaf (mm) without / with FLATSCAN	Max. door opening angle (°)	Rod assemblies (art. no.)	A (mm) without / with FLATSCAN	B (mm)	C (mm)
-30...+50	740 / 810	105	0548-105	140 / 210	280	620
51...80	760 / 810	100	0548-105	160 / 210	280	620
-30...+140	890 / 1'020	105	0548-105/02	80 / 210	385	830
141...180	910 / 1'020	100	0548-105/02	100 / 210	385	830
181...200	910 / 1'020	95	0548-105/02	100 / 210	385	830

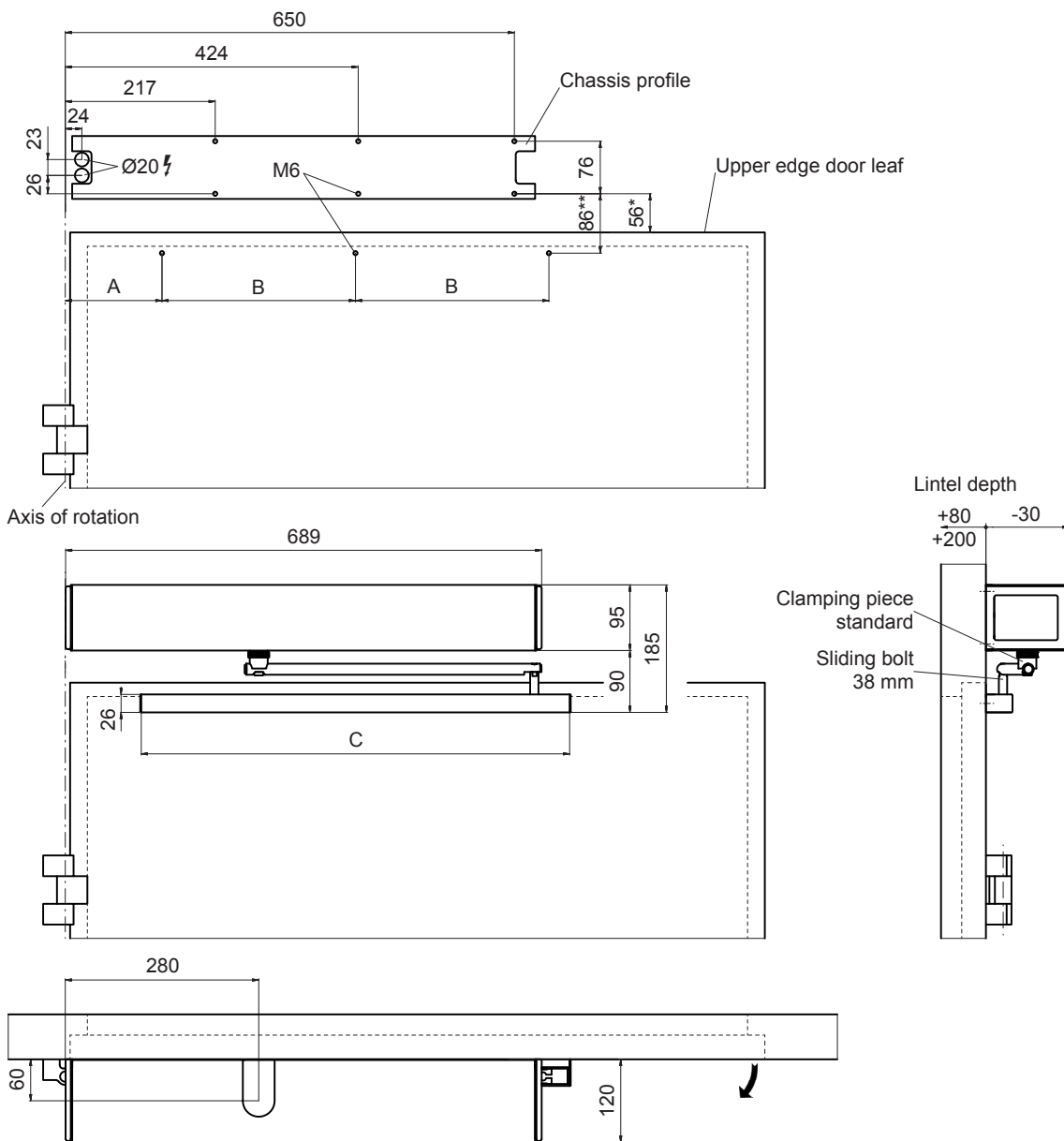

<u>Options</u>		*	**
0548-114	Clamping piece standard	51...73	86
0548-124	Clamping piece -13 mm	38...60	73
0548-125	Clamping piece +20 mm	71...93	106
0548-126	Clamping piece +50 mm	101...123	136

⇒ adjust the dimensions accordingly

Drive mechanism standard

2. Close the door leaf.
3. Install the mounting profile (E) on the door leaf.
4. Prior to the installation of the drive unit: screw down the lever arm (B) on the drive unit (with a 15° offset = 1 grid increment of the output shaft).

Note:

To facilitate the installation, the closing spring (H) can be completely released by means of the setting screw (I).

5. While mounting the drive unit, push the lever arm (B) back by the pre-stressing angle of 15°.
6. Push the guide profile (G) over the glider (C) and hook it into the mounting profile (E).
7. On both sides insert and screw down the expansion element (F) with 1,5 Nm.
8. Snap in the covering caps (D) on both sides.

⇒ forward to chapter 4.8

Inverse application

2. If existing:
Sub-assemble the drive-internal open position stop piece, integrated in the drive mechanism (see Option instructions 0548-992/02).
3. Mount the drive mechanism.
4. Install the mounting profile (E) on the door leaf.
5. Hook the guide profile (G) into the mounting profile (E), on both sides insert and screw down the expansion element (F) with 1,5 Nm.
6. Completely open the door leaf (max. 115°).
7. Insert glider (C) into guide profile (G) and screw down the lever arm (B) on the drive unit.
8. Snap in the covering caps (D) on both sides.

⇒ back to page 21



Attention:

Check the motional sequence of the door leaf:

The rods must not touch. If the glider (C) makes screeching noises, it needs to be lubricated with a little WD40.

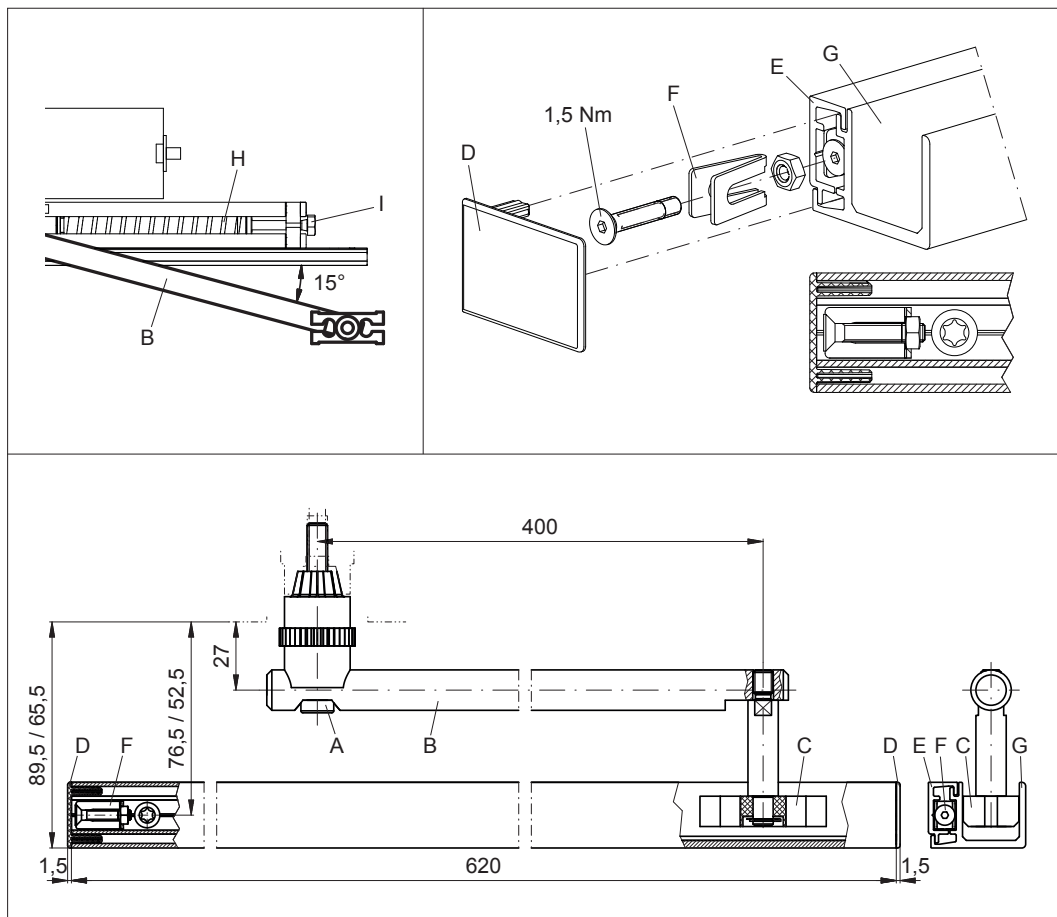

4.6 Sliding rods pushing function / Lintel mounting

Material:

1	Drive mechanism	0548-030	Covering aluminium
	Drive mechanism	0548-031	Covering inox
	incl. fixing set	0548-107	
1	Sliding rods	0548-134	620 mm incl. sliding bolts 14/38 mm
	Sliding rods	0548-105/02	830 mm incl. sliding bolts 14/38 mm

Procedure:

1. Mark out and drill the fastening holes on the lintel and the door leaf.



Note:

The illustration shows the 14 mm sliding bolt. Depending on the situation, this bolt can be replaced by the version 38 mm. This will change the respective dimensions by plus 24 mm.

Fixing holes

DIN right = as shown
 DIN left = mirror-inverted

Lintel depth (mm)	Min. width door leaf (mm)	Max. door opening angle (°)	Rod assemblies (art. no.)	A (mm)	B (mm)	C (mm)
-30...+20	740	105	0548-105	140	280	620
21...30	730	105	0548-105	130	280	620
31...40	720	105	0548-105	120	280	830
41...60	720	100	0548-105	120	280	830
61...70	720	95	0548-105	120	280	830
-30...+200	870	105	0548-105/02	60	385	830

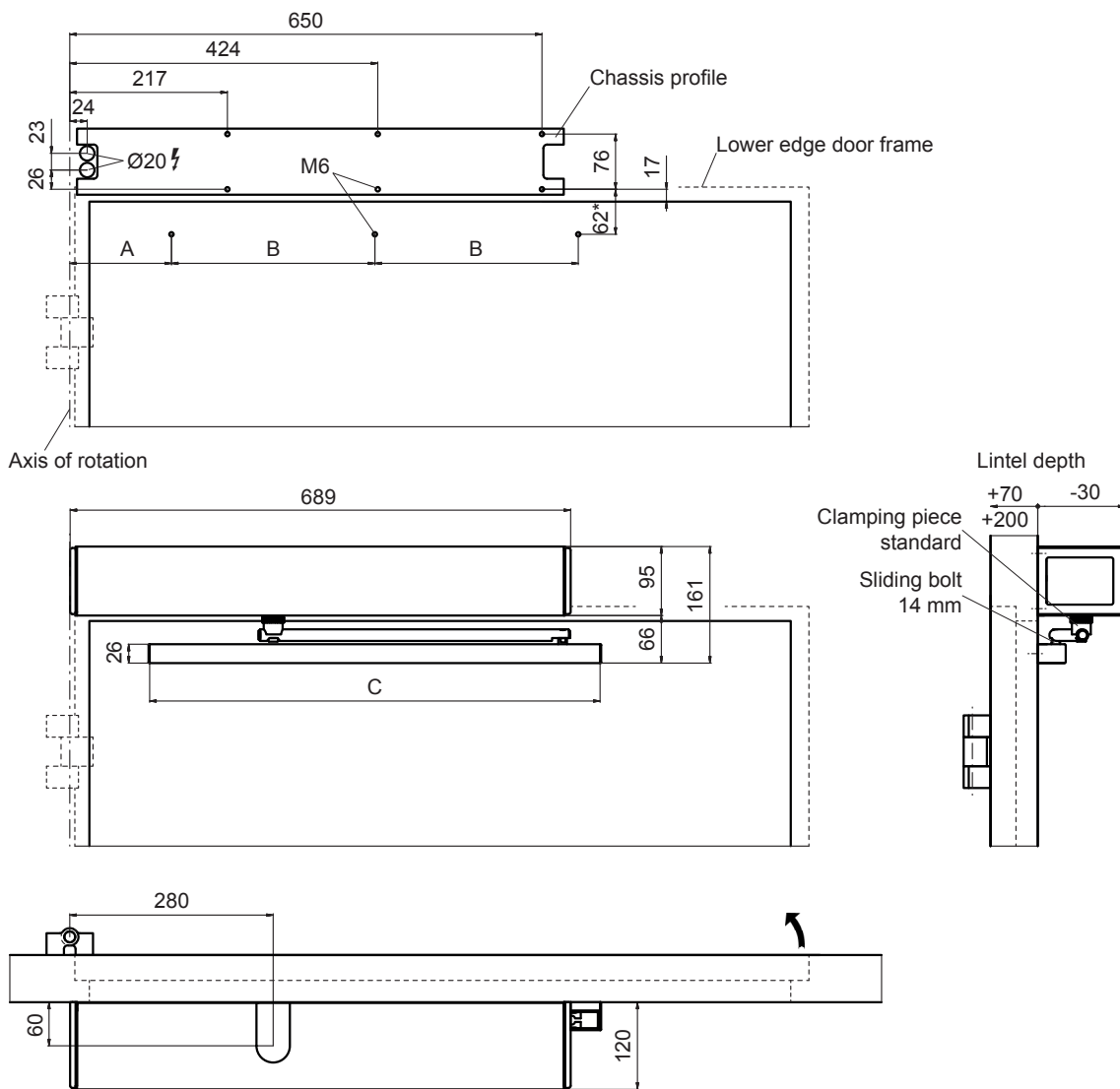

Options		*	**
0548-114	Clamping piece standard	10...18	62
0548-124	Clamping piece -13 mm	10...12	49
0548-125	Clamping piece +20 mm	10...38	82
0548-126	Clamping piece +50 mm	10...68	112

⇒ adjust the dimensions accordingly

Drive mechanism standard

2. Mount the drive mechanism.
3. Close the door leaf.
4. Install the mounting profile (E) on the door leaf.
5. Screw down the lever arm (B) parallel to the drive unit.
6. Push the guide profile (G) over the glider (C) and hook it into the mounting profile (E).
7. On both sides insert and screw down (with 1,5 Nm) the expansion element (F).
8. Snap in the covering caps (D) on both sides.

⇒ forward to chapter 4.8

Inverse application

2. If existing:
Sub-assemble the drive-internal open position stop piece, integrated in the drive mechanism (see Option instructions 0548-992/02).
3. Mount the drive mechanism.
4. Install the mounting profile (E) on the door leaf.
5. Hook the guide profile (G) into the mounting profile (E), on both sides insert and screw down (with 1,5 Nm) the expansion element (F).
6. Completely open the door leaf (max. 115°).
7. Insert glider (C) into guide profile (G) and screw down the lever arm (B) on the drive unit.
8. Snap in the covering caps (D) on both sides.

⇒ back to page 21

**Attention:**

Check the motional sequence of the door leaf:

The rods must not touch. If the glider (C) makes screeching noises, it needs to be lubricated with a little WD40.

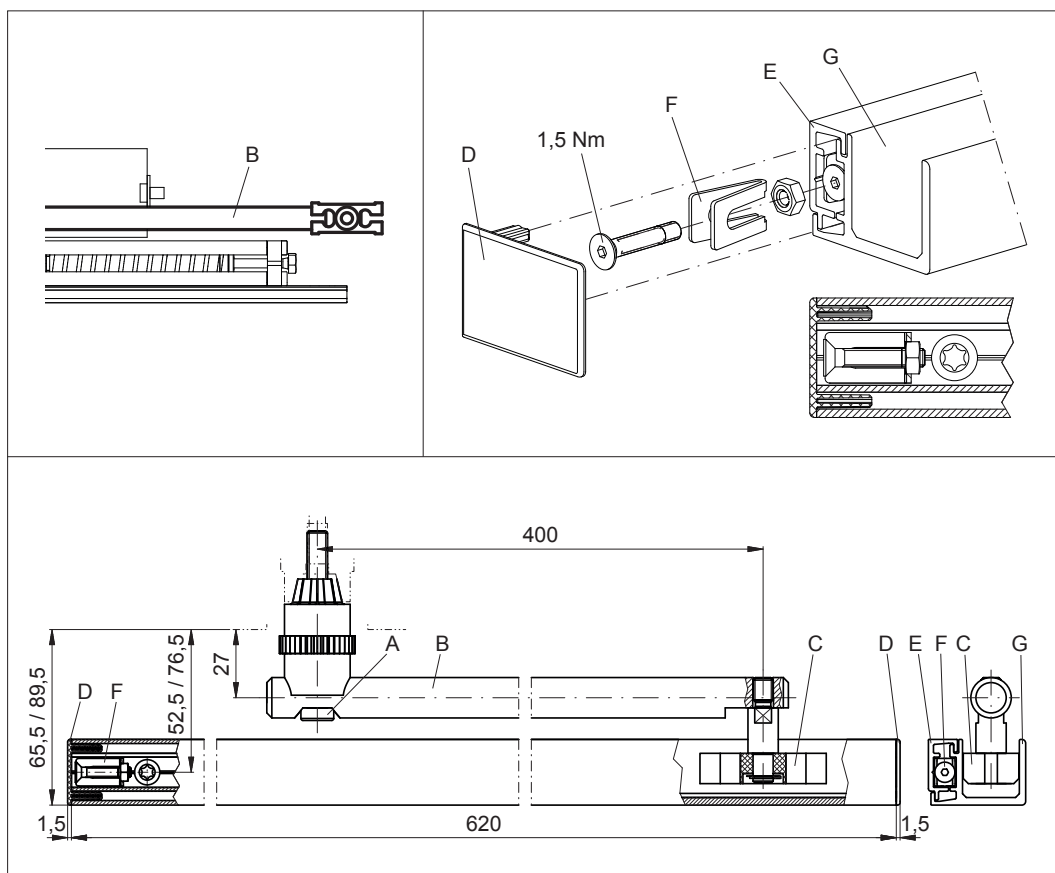

4.7 Sliding rods pushing function / Leaf mounting

Material:

1	Drive mechanism	0548-030	Covering aluminium
	Drive mechanism	0548-031	Covering inox
	incl. fixing set	0548-107	
1	Sliding rods	0548-105/02	incl. sliding bolts 14 mm + 38 mm and sliding rail 830 mm

Procedure:

1. Mark out and drill the fastening holes on the lintel and the door leaf.



Note:

The illustration shows the 14 mm sliding bolt. Depending on the situation, this bolt can be replaced by the version 38 mm. This will change the respective dimensions by plus 24 mm.

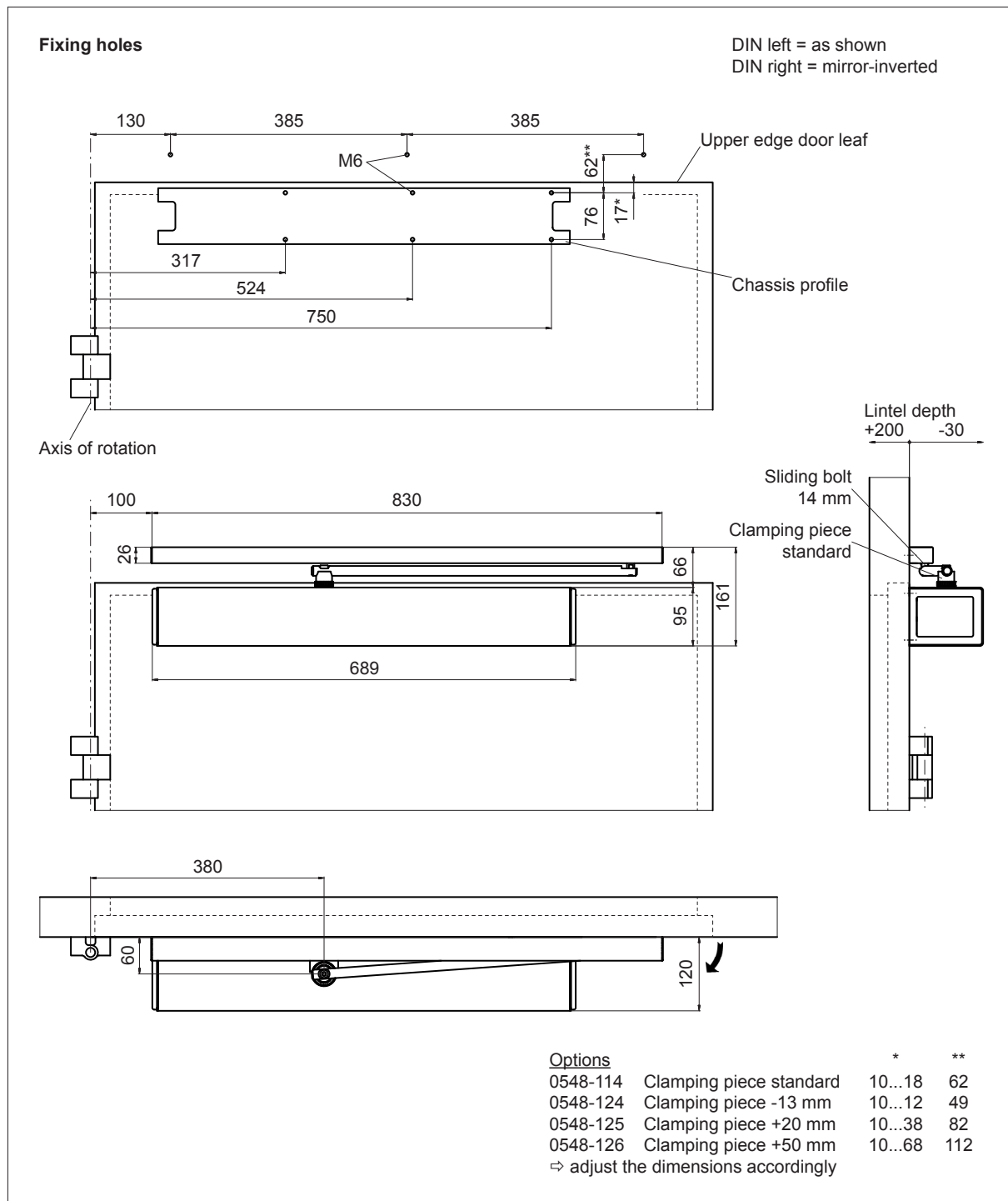

2. Mount the drive mechanism.
3. Close the door leaf.
4. Install the mounting profile (E) on the lintel.
5. Screw down the lever arm (B) parallel to the drive unit.

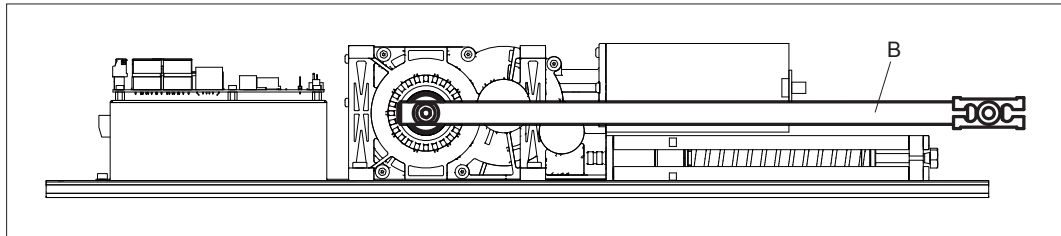

6. Push the guide profile (G) over the glider (C) and hook it into the mounting profile (E).
7. On both sides insert and screw down (with 1,5 Nm) the expansion element (F).
8. Snap in the covering caps (D) on both sides.



Attention:

Check the motional sequence of the door leaf:

The rods must not touch. If the glider (C) makes screeching noises, it needs to be lubricated with a little WD40.

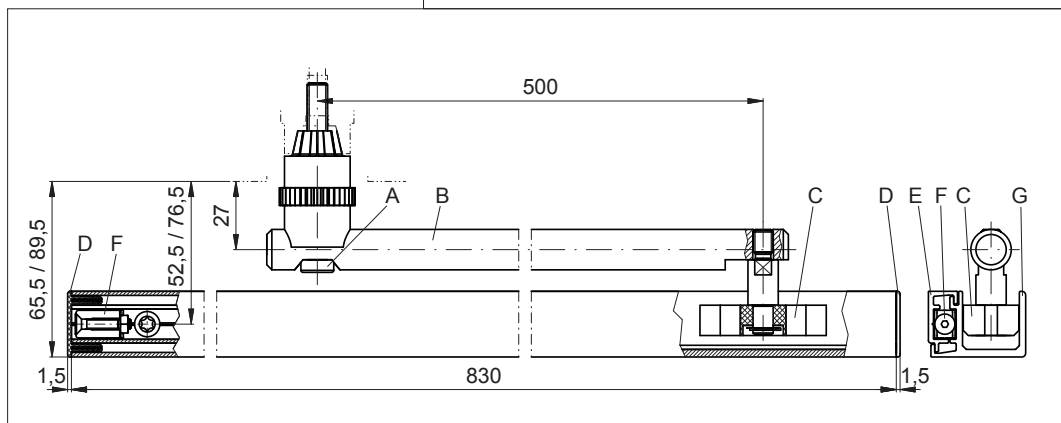
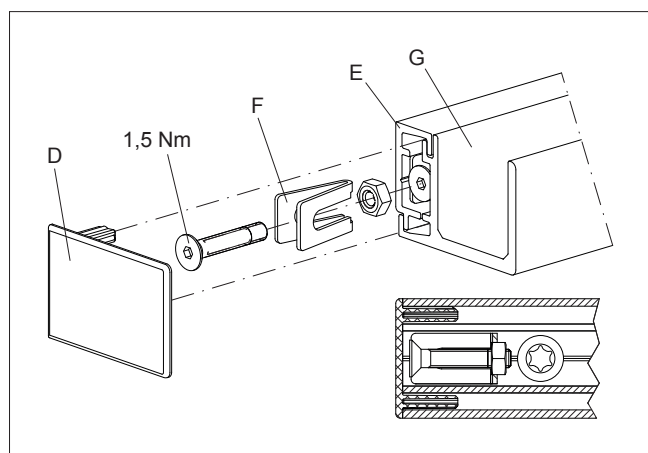

4.8 Adjusting the pre-stressing of the closing spring

Upon delivery, the closing spring is pre-stressed for a measure $X^* = 26$ mm. To ensure a safe and optimal operation of the swing door drive unit, the correct pre-stressing must be adjusted for the closing spring (by means of the setting screw).



Note:

The correct pre-stressing of the closing spring must imperatively be adjusted before carrying out the automatic setting-up procedure! The setting values are only mandatory for fire-protection and/or escape way doors. As a general rule, the closing spring force can be reduced when setting the standard drive unit. A possibly existing door lock must be correctly engaged to lock the leaf. Otherwise: adapt the pre-stressing of the closing spring accordingly.



Attention:

The setting screw needs to be shortened by 10 mm if it butts against the side cover's protection against accidental contact (with program selector key).

Procedure:

1. Close the door leaf.
2. Using the setting screw, adjust the measure X^* in function of the respective situation.
3. Open the door leaf by at least 60° and then let it be closed.

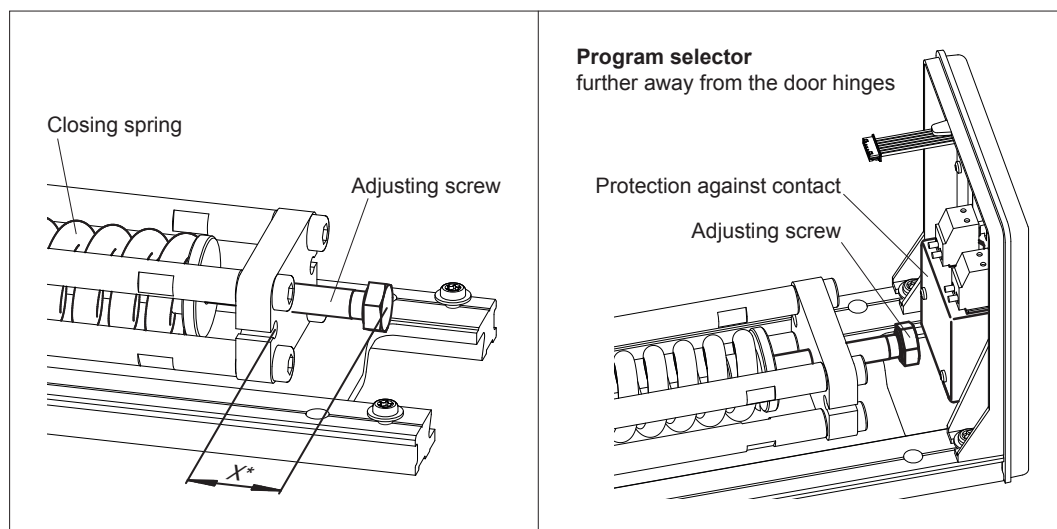

Drive mechanism standard

EN class	EN 3	EN 4	EN 5	EN 6	EN 7
Width of door leaf	950 mm	1'100 mm	1'250 mm	1'400 mm	1'600 mm
Closing torque 0...4°	18 Nm	26 Nm	37 Nm	54 Nm	87 Nm
Normal rods					
Measure X^*	37 mm	34 mm	29 mm	23 mm	20 mm
Sliding rods pulling function					
Measure X^*	34 mm	30 mm	23 mm	15 mm	12 mm
Sliding rods pushing function					
Measure X^*	32 mm	29 mm	22 mm	14 mm	12 mm

* Measure X is an approximated value for a lintel depth of 0 mm. The force necessary for manually opening a door must not exceed 150 N. This effort shall be measured as a static force on the main closing edge (perpendicularly to the door leaf), at a height of 1'000 mm \pm 10 mm.

Inverse application

EN class	EN 3	EN 4	EN 5	EN 6	EN 7
Width of door leaf	950 mm	1'100 mm	1'250 mm	1'400 mm	1'600 mm
Normal rods					
Measure X *	40 mm	36 mm	31 mm	27 mm	23 mm
Sliding rods pulling function					
Measure X *	38 mm	34 mm	29 mm	23 mm	20 mm
Sliding rods pushing function					
Measure X *	36 mm	33 mm	27 mm	20 mm	17 mm

- * Measure X is an approximated value for a lintel depth of 0 mm.
 Increase the spring tension only as little as necessary.
 The drive mechanism must be able to open the door leaf safely from any position.

4.9 Setting the accelerating function (forceful closing)



Note:
The accelerating function (forceful closing) is only activated for the standard drive unit.

4.9.1 Accelerating force

While an installation is in the state “without mains power” or in the operating mode MANUAL, the motor acts as an attenuator, thus guaranteeing a constant closing speed until the Closed position is reached.

To make sure that, when switched to the de-energized state or in the operating mode MANUAL, the door leaf is reliably engaged by the door lock, the drive unit is equipped with a door slam function (acceleration causing a forceful closing). By means of the potentiometer, the motor attenuation (shortly before the door leaf reaches the closed position) can be adjusted so that the pressure spring will have sufficient power for pushing the door leaf safely into the door lock.

Procedure:

1. Open the door leaf by 90° and then let it be closed.
2. Should the door leaf fail to engage in the lock, adjust the door slam cushioning by means of the potentiometer (provided on the control unit).



Warning:
In de-energized state or in the operating mode MANUAL, the closing procedure must last at least 3 seconds (from the open position 90° up to the closed position 0°).

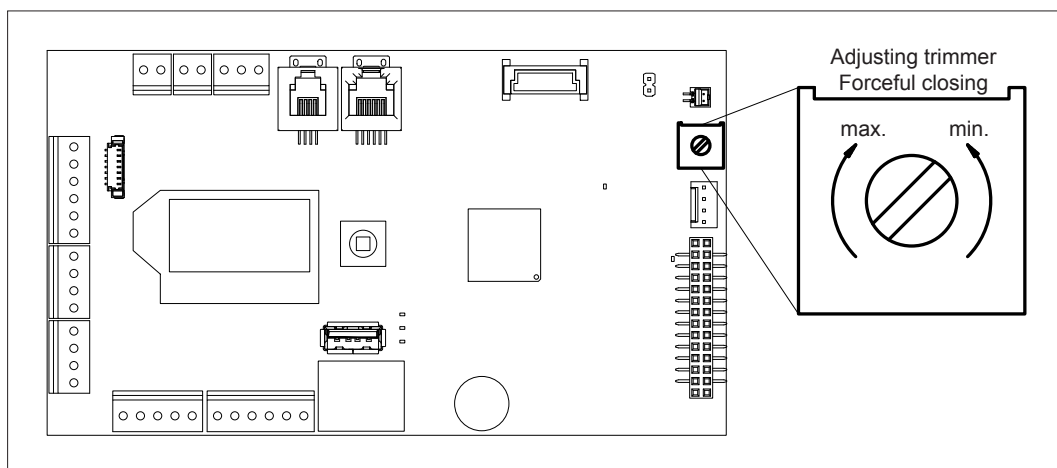

4.9.2 Forceful closing range

Upon delivery from the factory, the activation of the accelerating function (forceful closing) is pre-set (i.e. it intervenes approx. 5° before reaching the closed position). Under normal conditions, it will not be necessary to change the default setting! However, in cases where in the de-energized state or in the operating mode MANUAL the door leaf fails to be reliably engaged in the door lock, the activation point of the accelerating function (forceful closing) can be shifted (by means of a continuously adjustable cam disk).



Note:

The setting range is between 5 and 15° of the door opening angle.

Procedure:

1. Using a screwdriver, carefully prize the service cover (C) out of the gearbox housing.
2. By means of a socket wrench 1,5 mm, slightly loosen the locking screw (B), then carefully turn the cam disk (A) to the left or to the right.
3. Tighten the locking screw (B).
4. Open the door leaf by about 45° and then let it be closed. Check whether the door leaf is correctly pushed into the door lock.
5. Snap the service cover (C) into the gearbox housing.

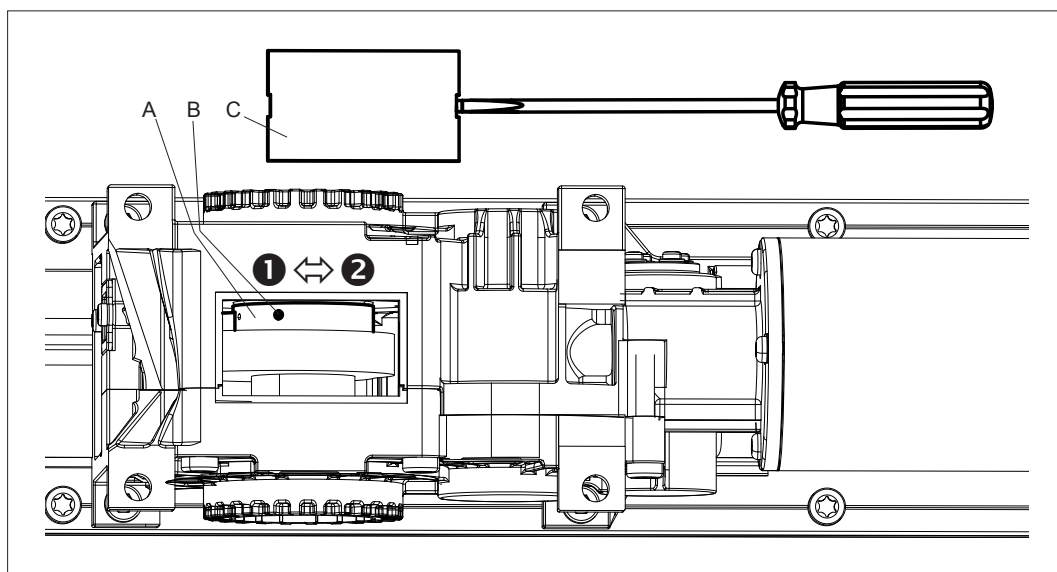

- | | |
|---|--|
| <p>1 Sliding rods pulling function / Lintel mounting
 Normal rods pushing function / Lintel mounting
 Sliding rods pushing function / Lintel mounting
 Sliding rods pushing function / Leaf mounting</p> | <p>Angle smaller
 Angle bigger
 Angle bigger
 Angle bigger</p> |
| <p>2 Sliding rods pulling function / Lintel mounting
 Normal rods pushing function / Lintel mounting
 Sliding rods pushing function / Lintel mounting
 Sliding rods pushing function / Leaf mounting</p> | <p>Angle bigger
 Angle smaller
 Angle smaller
 Angle smaller</p> |

5 ELECTRICAL CONNECTIONS

5.1 Power supply



Warning:

Before working on the drive unit, make sure that the mains cable is voltage-free!
The mains supply line including mains plug (with respective protection) has to be provided by customers.

The mains supply cable 230 VAC must imperatively be routed below the chassis profile, whereas the cables of the control and safety elements can be routed within the drive unit.

Procedure:

1. If required: break out the pre-perforated flap on the side cover.
Depending on the assembly situation, it may be advisable to install the program selector on the opposite side.
2. Connect the mains supply cable as illustrated (see also wiring diagram E4-0141-713_ECO in the appendix).
3. Mount the side cover.

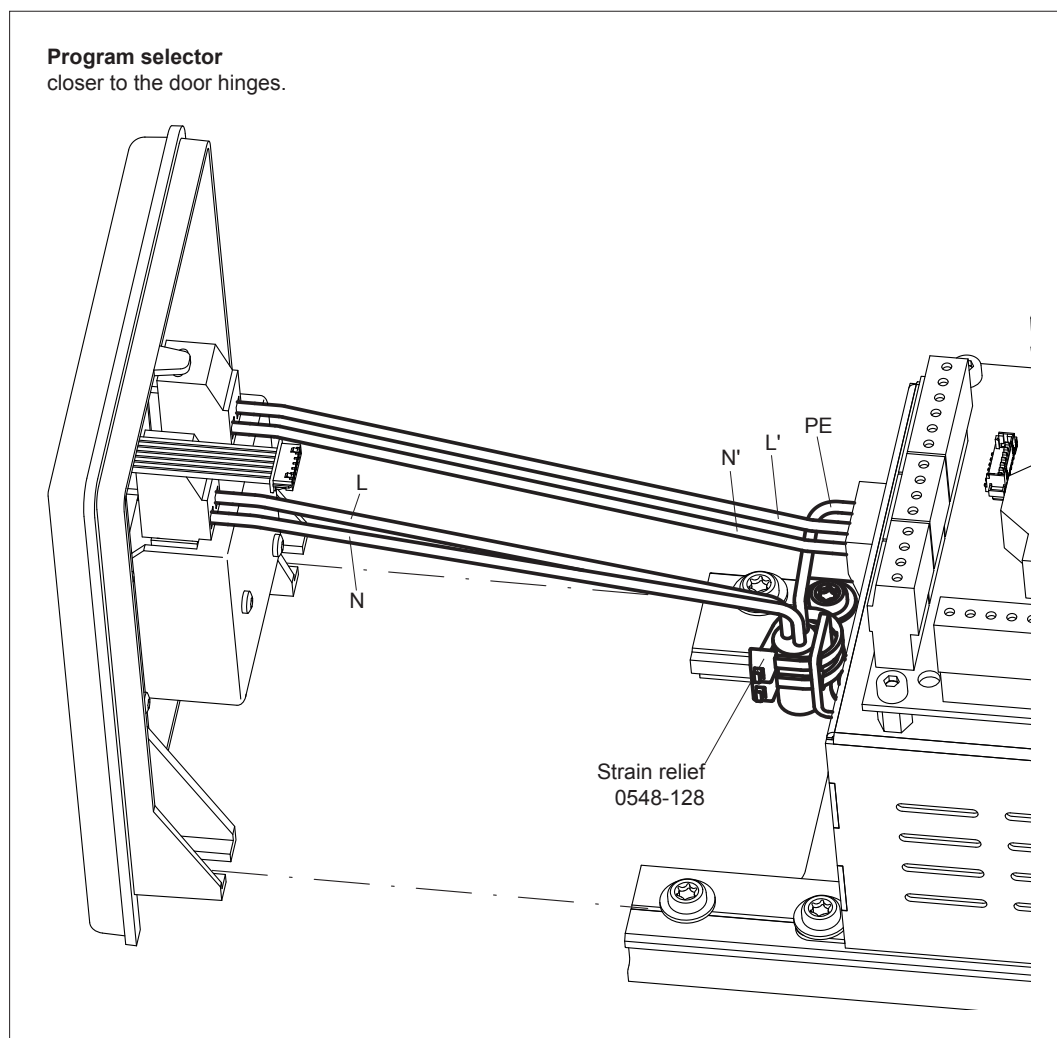

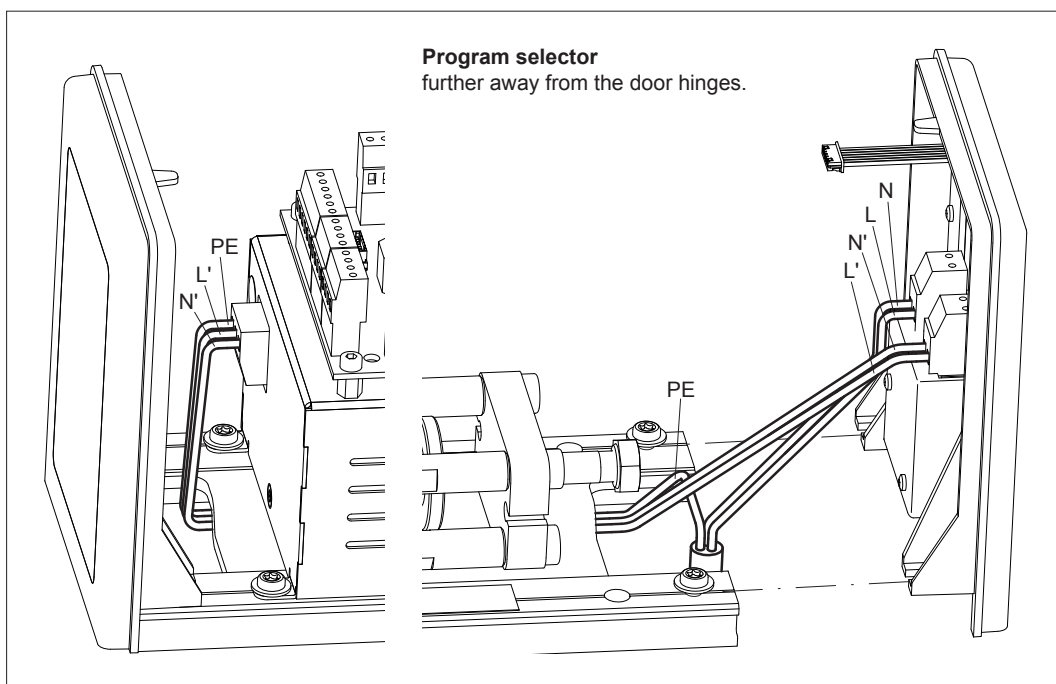
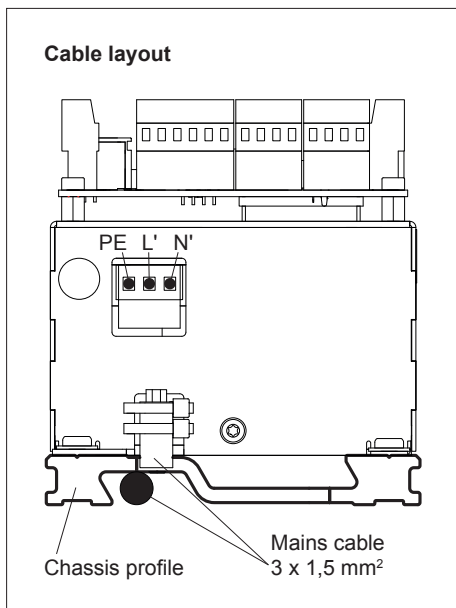

5.2 Cable layout

5.2.1 Lintel mounting

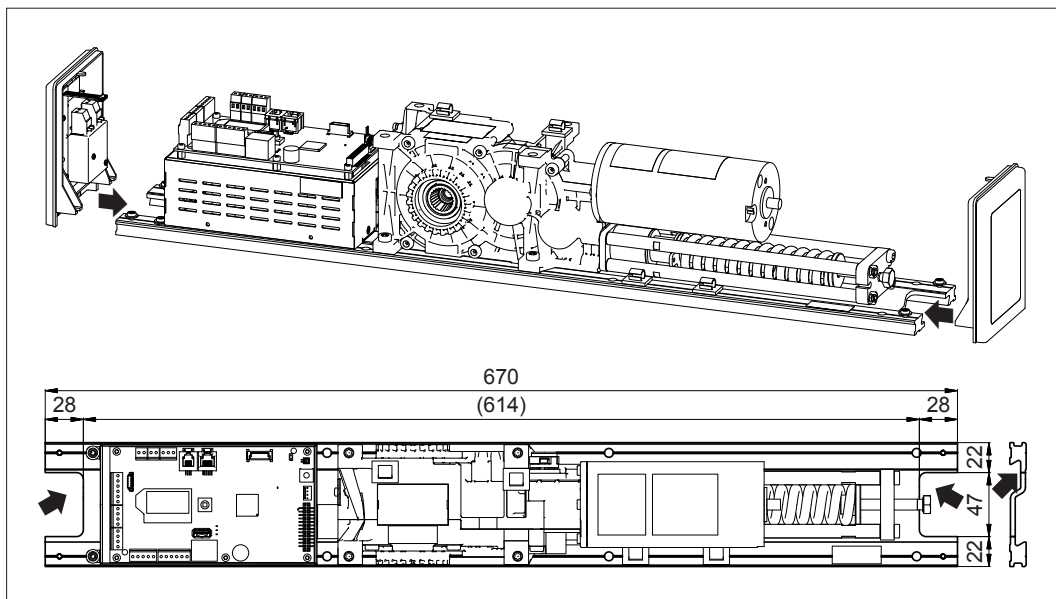

5.2.2 Leaf mounting

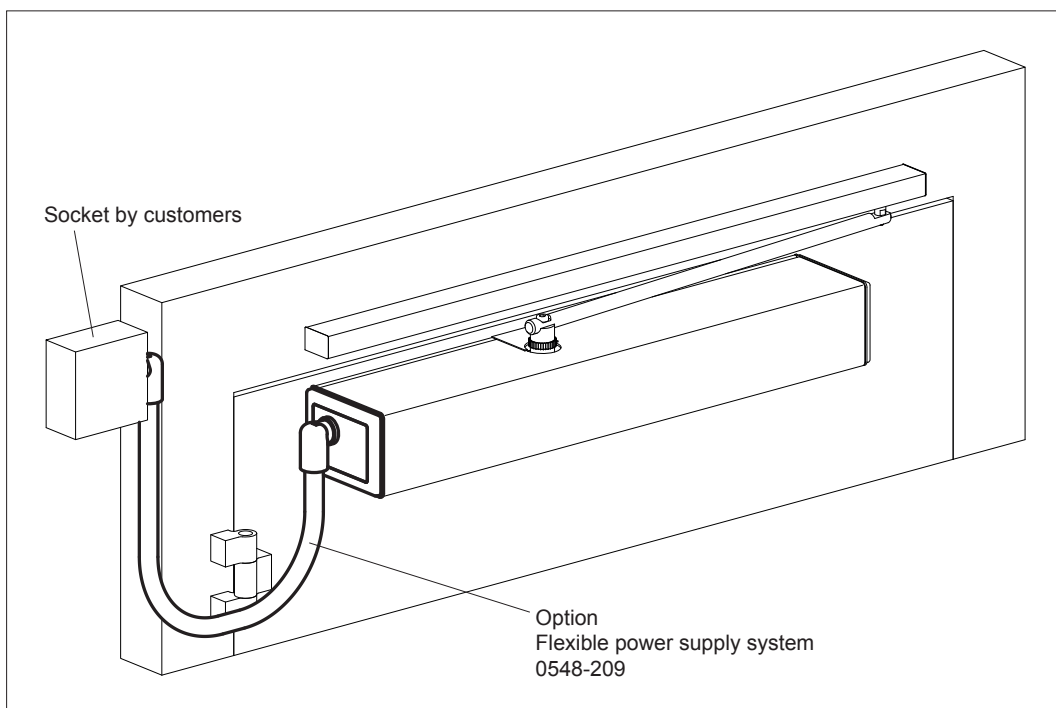

5.2.3 Strain relief



Attention:

For flexibly conducted cables, the drive-internal strain relief feature 0548-128 and a bushing socket must be installed in the side cover cutout!

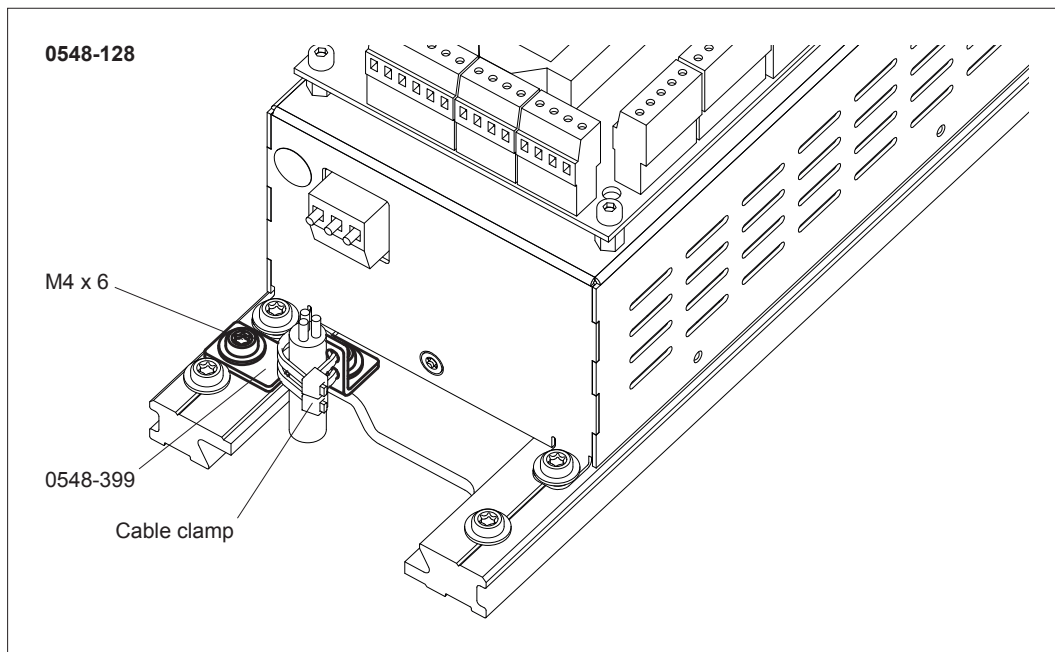

5.3 External elements

1. Mount all the required control and safety elements at their respective place.
2. Lead the cables of the elements up to the drive unit (by customers).
3. Connect the cables according to the diagram E4-0141-713_ECO (in the appendix).



Note:

If an electric lock is provided, its connection rating is 24 VDC and max. 0,8 A (or 24 VAC/1,5 A by customers). It should be designed for a duty cycle of 100 %. The electric lock locks the door leaf in the desired operating modes and is configurable.



Attention:

For the Inverse application we advise to use an electric lock or a holding magnet which maintains the door leaf in the closed position and must answer the following requirements:

- tested and homologated for escape and rescue ways
- opening also under preload (load-independent unlocking without jamming)
- 24 VDC / 100 % duty cycle
- opening without mains power (normally open)

Without this electric lock, the drive unit needs to apply a continuous closing pressure and push the leaf against the spring power (at the cost of increased power consumption).

In case the Inverse application is used for installations RWA (smoke and heat exhaust vent solution), it is compulsory to use the drive mechanism ETS 64-R!

5.4 Motorized lock

The swing door drive mechanism and its control unit are always configured as Master. All the commands are transmitted to this control unit. The latter then unlocks/locks the motorized lock.

Functional performance:

Opening command



Impulse and permanent command transmitted to motorised lock (CONFIG Unlock: IMPULS or PERMAN)

Locking latch opens



Starting delay TDelay to be set between 0,0...4,0 s or a feedback can be connected on terminal 32.

Drive unit opens



Hold-open time expires

Drive unit closes



Motorised lock locks

provided that no command for the motorized lock is pending (to be set under CONFIG Unlock = PERMAN, operating modes Automatic, Exit, Manual)



Note:

The following lists of motorized locks are not necessarily exhaustive. Please take into account the modifications communicated by the motorized lock manufacturers! Also see wiring diagram E4-0142-180_ECO in the appendix.

5.4.1 Motorised lock with direct connection to motor coil

Some motorized locks can be directly controlled from the control unit of the swing door drive mechanism (direct connection of motor coil). In order to enable this configuration, the motorized lock must fulfill the following requirements:

- 24 VDC / max. 1,5 A
- Possibility to connect a release signal directly on the motorized lock.

Designations	Terminals				Remarks
Swing door drive mechan.	1 24 VDC	30 EL-NO	28 GND	32 EL-Fb	-
FlipLock drive	1	3	2	5	CONFIG EL-Fb = N.C. PARAMETER TDelay = 0

5.4.2 Motorized lock with own evaluation control

The motorized lock is equipped with an own evaluation control (either integrated or external). The swing door drive mechanism is configured as the Master unit and transmits a voltage free impulse for control unit of the motorized lock for relasing the latter. The electric power is supplied directly via the swing door drive mechanism (i.e. the motorized lock does not require its own power pack).

Designations	Terminals						Remarks
Swing door drive mechan.	1 24 VDC	3 GND	29 EL-COM	30 EL-NO	28 GND	32 EL-Fb	-
G-U BKS B 1956/1959	13	14	-	9	5	6	CONFIG EL-Fb = N.C. For obtaining a motorized daily release, the seal as well as the board immediately behind it must be pierced and the lock must be restarted. Attention: Daily release is not allowed for fire safety doors!
G-U/BKS Security Automatic	1	2	-	3	-	-	Connect terminals 1 and 29 on the swing door drive mechanism. With fire safety doors, it is compulsory to use an external power supply.
Effeß 509X/529X with control unit 509XSTRG (EA420)	1	2 / 12	18	16	-	13	CONFIG EL-Fb = N.O.
Schüco motor unit for SafeMatic and InterLock	white	brown	-	green	-	-	Connect terminals 1 and 29 to swing on the swing door drive mechanism.
Dorma SVP 2000 with control unit SVP-S 2x	21	23	23	28	47	48	CONFIG EL-Fb = N.O. PARAMETER TDelay = 0 Attention: For fire safety doors, it is compulsory to use module SVP-PR12!
Dorma M-SVP 2000 DCW Dorma M-SVP 2200 DCW (Stand-Alone)	1	3	3	28	-	-	-

5.4.3 Motorized lock with separate evaluation control/power pack

The motorized lock is equipped with a separate evaluation control and a separate power pack ensuring the power supply. The swing door drive mechanism is configured as the Master and transmits a voltage free impulse to the control unit of the motorized lock for releasing the latter.

Designations	Terminals						Remarks
Swing door drive mechan.	1 24 VDC	3 GND	29 EL-COM	30 EL-NO	28 GND	32 EL-Fb	-
MTSFlip Lock access	-	-	36	37	-	-	-
MTS anti-panic lock M-9300 with control unit	-	-	2	5	20	21	-w
Fuhr autotronic 834 Fuhr autotronic 834P (anti-panic function for fire safety doors) Fuhr multitronic 881 Fuhr multitronic 881GL with control housing, top hat rail control or control box	-	-	9	10	3	4	CONFIG EL-Fb = N.C. PARAMETER TDelay = 0
Dorma M-SVP 3000 with control unit	-	-	9	10	3	4	CONFIG EL-Fb = N.C. PARAMETER TDelay = 0

6 COMMISSIONING



Warning:
 During the setting-up procedure (which must only be carried out by experts), the safety devices (radar, sensors, ...) are switched off!
 Before initiating the setting-up procedure, it is important to make sure that neither persons nor objects remain within the danger area of the moving door leaf, in order to avoid injuries or damages!



Attention:
 Make sure that the motor connector plug has been correctly plugged into the control unit (see chapter 4.1 and 4.2).

Procedure:

1. Switch on the mains supply switch on the side cover (power-up).
2. Using the joystick, adjust the display direction: Move the joystick downward once ⇒ the display direction is switched to a readable position.
3. Programming the type of rod assembly Rod:
 Move the joystick to the left/to the right (see parameter chapter 7.4). Validate the correct type of rod assembly by means of OK: In the rest position, shortly push in the joystick.
4. Adjust the distance dAxis (distance in cm between the rotation axis of the door hinges and the mounting level of the drive unit ⇒ see illustration below).

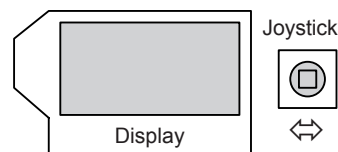

Press
Down

Rod
STD-PH

dAxis
5cm



Note:
 dAxis is an approximate value. Depending on the installation situation, dAxis may have to be adapted.



5. Adjust the opening angle Ao and validate by means of OK.

Ao
95°

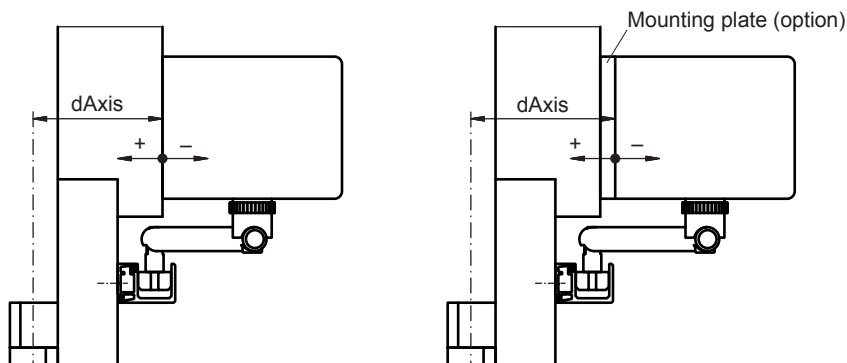

Attention:
 The steps 4 and 5 are influenced by the installation measures/distance between the door hinges.



- | | |
|---|---|
| 6. Adjust the opening speed V_o and validate by means of OK. | Vo
6 |
| 7. Adjust the closing speed V_c and validate by means of OK. | Vc
4 |
| 8. If desired:
Program the inverse application (spring-powered opening) and validate it by pressing OK. | Invers
OFF |
| 9. Adjust the setting-up procedure (Teach) and validate by means of OK. | Teach |
| 10. Start the setting-up procedure (Teach): validate by means of OK. | Teach
ok? |
| 11. Upon expiry of 10 seconds the setting-up procedure (Teach) is automatically initiated (or immediately by means of moving the joystick $\leftarrow \uparrow \rightarrow \downarrow$ without OK). During the setting-up procedure the drive unit continues to beep. The following learning run is carried out: <ul style="list-style-type: none"> • Inverse: First the system searches for the closed position by moving at super-slow speed. • Super-slow speed opening direction • Super-slow speed closing direction. | Teach1
x E10 |
| | Teach2
x E10 |
| 12. Upon completion of the learning run the following message is displayed: | Done !
x E11 |
| 13. The display should now supply the following information:
E11 indicates that the setting-up procedure (Teach) is not yet completed. | >##<
 E11 |
| 14. By giving an opening command, open the door leaf and let it be closed again. The door leaf will open and close at normal speed (without obstacle detection feature).
Remark:
The door leaf must not be obstructed!
Now the display should provide the following information:
The setting-up procedure (Teach) is now completed. | >##<
 |

**Note:**

A renewed setting-up procedure (Teach) is required if:

- the spring tension has been changed
- the leaf weight has been changed
- the type of rod assembly has been changed
- the opening angle A_o has been changed
- the Teach has been obstructed before reaching an opening angle of 20°
- the distance between axles (dAxis) has been changed
- the parameter Invers has been changed.

Additional parameter and menu navigation \Rightarrow see chapter 7.4.

6.1 Inverse application



Attention:

The starting delay TDelay must be > 0 s and the relieving force during unlocking FDelay must be adjusted in accordance.

Software configuration:

- Activate the parameter Inverse.
Attention: the motor connector must not be plugged in the same manner as for the standard drive unit.
- The electric lock must be unlocked without mains power or powered by an external source.
- For installations without an electric lock, the interlocking force Fch must be programmed.
- If there is no electric lock and the interlocking force Fch is not adjusted, error 14/02 will be displayed as a warning after the teach-in procedure. This means that the door leaf will endlessly re-open.

Starting-up and teaching:

- The door leaf is closed at super-slow speed. The safety sensory system is active (except during the teach-in procedure).
- Start the teach-in from the open position: This ensures the teach-in of the necessary current for the possible angle between the mechanical open stop piece and the programmed open position Ao.
- Closing sequence control: During start-up and teach-in the door leaves are synchronized (in order to avoid a possible collision). The installation is only ready for operation as soon as both door leaves are closed respectively after the teach-in procedure has been completed.

6.2 Closing sequence control

For bi-parting installations, the closing sequence control determines the order in which the door leaves are opened and closed. For the opening procedure, the earlier door leaf (Master leaf) is the first one to be opened, whereas for the closing procedure the delayed door leaf (Slave leaf) is the first one to be closed. This sequence ensures a correct overlapping of the door leaves.

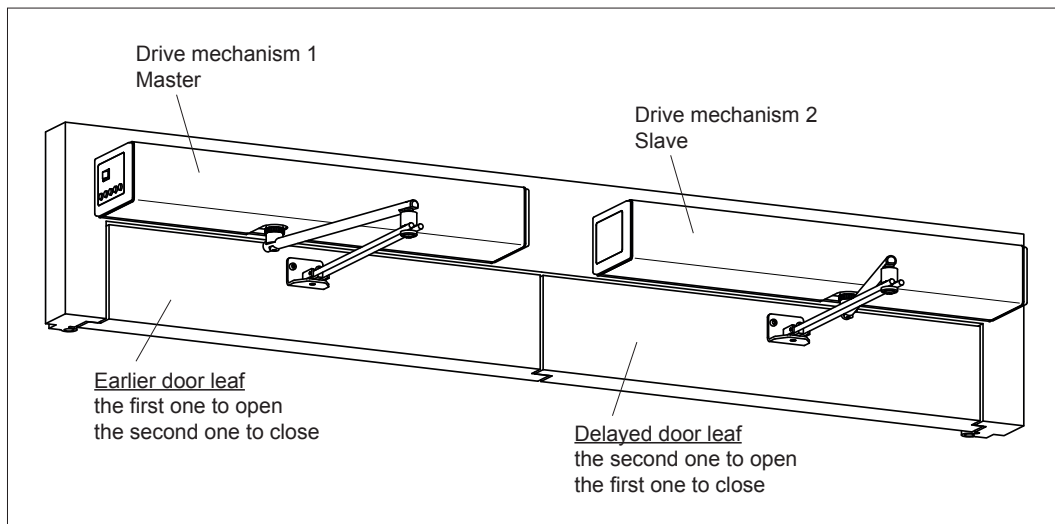

Connections:

Opening elements (KE, OEO and OEI) connected to Master only act upon the Master (single leaf operation). Opening elements connected to Slave act upon the Master as well as on the Slave (bi-parting operation).

The safety elements SER and SES are connected to the respective drive unit.

An active EMCY element connected to the Master carries out the EMY-IN action configured on the Master (for both door leaves). An active EMCY element connected to the Slave switches the latter to the spring-powered operation.

An electric lock, which locks the Master leaf, is connected to the Master. Accordingly, an electric lock, which locks the Slave leaf, is connected on the Slave.

Function:

The first door leaf to be put in motion for the opening procedure is the Master; by means of DupleD, this leaf is configured as MastrA. Its partner is the Slave, which is configured as SlaveA by means of DupleD.

In the event of an existing CAN connection, the Master is identified by a small black (m) and the Slave by a small black (s). If however there is no connection, this is indicated by a small white (m) respectively a small white (s).

The parameter settings for the Master and the Slaves are entirely independent from each other. It is thus possible to select a $V_o = 4$ for the Master and a $V_o = 5$ for the Slave.

In order to guarantee a collision-free opening of both door leaves, the Slave leaf lets the Master leaf go ahead and initiate the opening. This time lag can be defined on the Slave by means of AoSeq. The default value of AoSeq is 20° , which is sufficient for most of the bi-parting installations. This means that the Slave only starts to open after the Master has exceeded an opening angle of 20° .

From then on, it is admissible for the Slave to catch up with and pass the Master if this should be required. This is done by configuring a higher V_o value for the Slave than the one for the Master.

In cases where (due to an electric lock connected to the Master) TDelay of the Master is configured with a higher value than 0,0 s, then the angle between the Slave and the Master is accordingly increased. To compensate this, AoSeq can be reduced in accordance. An AoSeq value of 0° means that both door leaves will be simultaneously opened, i.e. that no opening delay is active.

The default value of AcSeq is 20° and thus sufficient for the majority of bi-parting installations. In cases where a mechanical closing sequence regulator is used with a mechanical closing delay of e.g. 90° , AcSeq must be programmed with a value of 90° or more.

AcSeq 20° means: The Master only starts closing as soon as the Slave has gained a lead of 20° . This advance guarantees that the Master will be closed in one go (without intermitence), which results in an optically pleasing closing motion.

The Master is allowed to overtake the Slave. 20° (value AcSeq) before reaching the closed position, the Master checks whether the Slave is already closed. If not, the Master will perform an intermediate stop in order to prevent a collision.

An active SES signal on a door leaf causes a safety stop of both door leaves. The same applies for the SER signal. An active SER signal causes both door leaves to reverse their motion.

A bi-parting installation can be operated in the single-leaf mode. An active EMCY signal on the Slave programs the closing sequence as a single-leaf configuration.

If only the EMCY signal on the Master is active, then this EMCY signal is applicable for both door leaves. In accordance with the action configured on the Master by means of EMY-IN, both door leaves carry out a CL-SPR (Close Spring), STOP, OPEN or CL-MOT (Close Motor).

If only the EMCY signal on the Slave is active, then the Slave carries out a CL-SPR, regardless of the action configured on the Slave by means of EMY-IN.

If both EMCY signals are active, then the Master performs its configured EMY-IN action and the Slave performs a CL-SPR. One exception of this rule is the Master in the EMY-IN configuration OPEN. In this case, both door leaves will be opened.

Procedure:

1. Connect both control units by means of the CAN cable 0383-194/07 (by plugging it into the socket X117).

**Note:**

The respective control and safety elements are connected to the corresponding drive unit.

2. Take the Master drive unit into operation (see chapter 6).
3. For the Master drive unit: Select the operating mode OPEN.
4. Take the Slave drive unit into operation (see chapter 6).
5. Configuration of the Master drive unit:
 - DupleD = MastA
 - AcSeq = desired time lag of the closing angle.

**Note:**

In cases where a mechanical closing sequence regulator is used, start with a AcSeq of 90°; afterwards AcSeq can be reduced.

6. Configuration of the Slave drive unit:
 - DupleD = SlaveA
 - AoSeq = desired time lag of the opening angle.

Control:

1. Check the display of the Master control unit to see if a small black (m) is visible on the first level (connection existing). On the display of the Slave control unit, a small black (s) must be visible.

**Note:**

A small white (m) resp. (s) indicates: missing connection.

2. Transmit a Key command to the Slave drive unit:
 - The Master-drive unit is the first one to open, followed by the Slave drive unit (which is delayed by the value of the opening angle).
 - In the open position the hold-open time expires on the display of the Slave control unit.
 - The Slave drive unit is the first one to close, followed by the Master drive unit which is delayed by the value of the closing angle).

6.3 Interlock operation

Procedure:



Note:
Both installations must be plugged into resp. out of the same power supply.

1. Connect both control units by means of the CAN cable (by plugging it into the socket X117).
2. Normal commissioning of both drive units.
3. Configuration of the drive unit for the exterior door (A):
 - InterL = SideA
4. Configuration of the drive unit for the interior door (B):
 - InterL = SideB

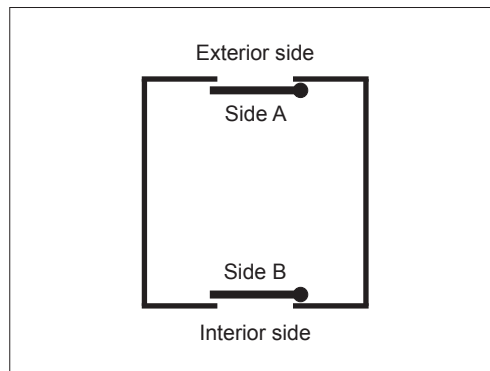

Control:

1. Check the display of the Master control unit to see if a small black (w) is visible on the first level (connection existing).



Note:
A small white (w) indicates: Missing connection.

2. Transmit a Key command to the exterior door (A):
 - On the display a big black (W) appears (door is not closed).
 - While the exterior door (A) is open, transmit a Key command to the interior door (B) (the latter must not be opened).
3. Transmit a Key command to the interior door (B):
 - On the display a big black (W) appears (door is not closed).
 - While the interior door (B) is in the open position, transmit a Key command to the exterior (A) (the latter must not be opened).



Note:
The parameters ILAuto, ILExit and ILNigt enable you to configure the operating modes in which the interlock system shall be active.

6.4 Adhesive labels

6.4.1 Service sticker

1. Attach the service sticker (outside) onto the degreased surface of the drive unit covering, at a place that is easily visible for the customer.
2. Stick the monthly sticker onto the service sticker, turning the monthly sticker until the checking date matches the arrow.
3. Using a water-proof felt tip pen, enter the year of the next checkup on the monthly sticker.

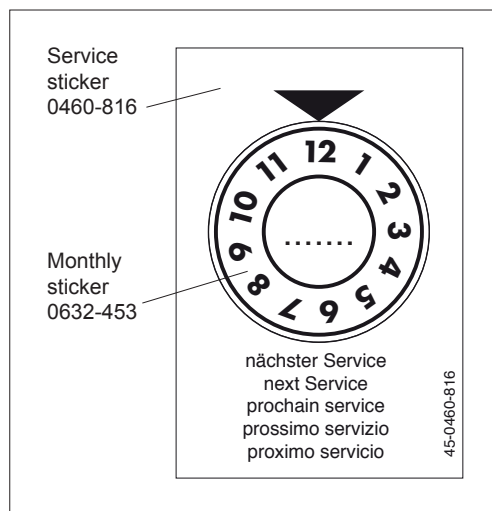

6.4.2 Diagram sticker

1. After cleaning and degreasing the gluing surface, attach the diagram sticker (in the respective language) to the inside of the covering.

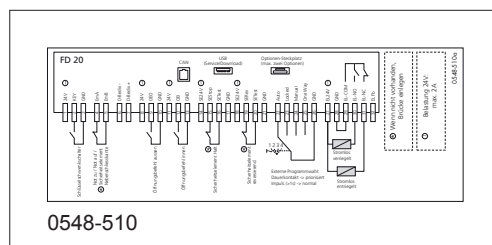

6.5 Mount the drive unit covering

Material:

1	Covering	0548-356	Aluminium
1	Covering accessories	0548-112	Aluminium
or			
1	Covering	0548-303	Stainless steel
1	Covering accessories	0548-115	Stainless steel

Procedure:

1. Mount the covering and the accessories as shown in the illustration.

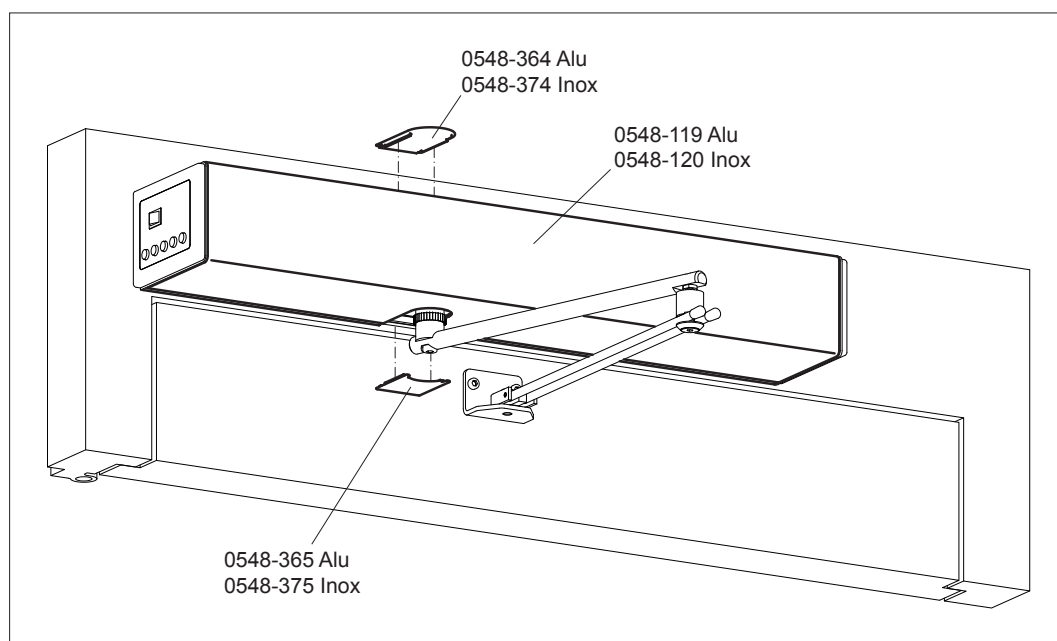

7 CONTROL

7.1 Main switch

The drive mechanism is supplied with a built-in main switch (A). This main installation switch enables you to disconnect the power supply from the drive unit. The door leaf then is closed from any position by means of spring power (Invers = spring opening, unless the door leaf has not been locked). The motor attenuation ensures a controlled closing (Invers = opening).

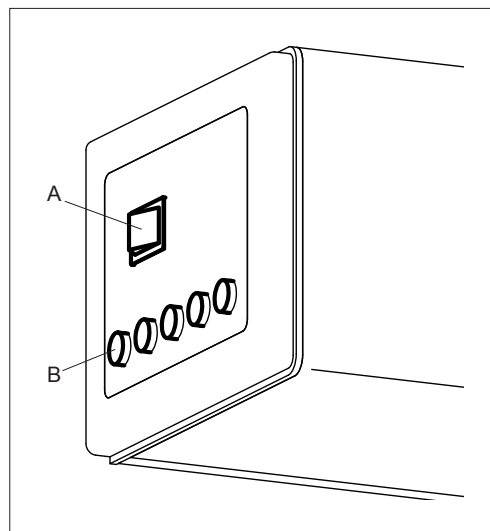

7.2 Program selector

The drive mechanism is supplied with a built-in program selector (B), which allows enabling the operating modes AUTOMATIC, NIGHT, OPEN, MANUAL and EXIT. The presently enabled operating mode is identified by the illuminated key.



Note:

In the event of a pending fatal error, all the keys shortly flash up.

Key lock (3 versions)

1 Fix

One particular program setting has been predefined by default. This setting can only be overridden by an external program switch or a timer.

2 Toggle

Locking:

Press the active program key during at least 5 seconds. The locking is signaled by a short blip.

Unlocking:

Press the active program key during at least 5 seconds. The deactivation is signaled by two short blips.

3 Time

Locking:

If the program keys have been activated within a period of 5 minutes, they are automatically locked.

Unlocking:

Press the active program key during at least 5 seconds. The deactivation is signaled by two short blips.

7.3 Operating modes

The following operating modes can be enabled by means of the program selector:



AUTOMATIC

Automatic opening via the opening elements inside/outside + Key.
Automatic closing upon expiration of the adjustable hold-open time.



NIGHT

The door leaf can only be opened via the opening element Key (key-operated switch outside).



OPEN

The door leaf is automatically opened and remains in the OPEN position.



MANUAL

The drive mechanism and the control elements are switched off.
The door leaf can be manually opened.
The door leaf is closed by spring power from any position (Invers = spring opening, unless the door leaf has not been locked).



EXIT

The door leaf can only be opened via the opening elements inside and Key.



+



Setting-up procedure (Teach)

Completely close the door leaf (Invers = open). Hold the keys MANUAL and EXIT simultaneously depressed (during at least 5 seconds). All the pending errors will be deleted and a setting-up procedure (Teach) is carried out.

7.4 Adjustings

The parameters can be changed on the control unit by means of the display and the joystick.

The movements of the joystick have the following effects:

- Vertical joystick movement (upward/downward) ⇒ Scroll through the displayed information.
- Horizontal joystick movement (to the left/to the right) ⇒ Change the settings.
- Shortly press in the joystick in the rest position ⇒ Validation OK.

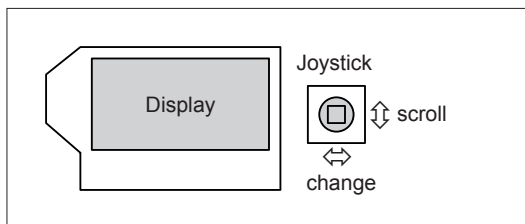

7.4.1 Motional parameters (PARAMETER)

Parameter	Description	Setting range	Default
Vo	Opening speed (velocity open)	0..14 (5...50°/s)	6
Vc	Closing speed (velocity close)	0..14 (5...50°/s)	4
TOEx	Hold-open time opening element inside/outside (time hold opening element inside/outside)	0...60 s	3 s
TKey	Hold-open time Key (time hold opening element Key)	0...180 s	5 s
TDelay	Starting delay (time delay lock)	0,0...4,0 s	0,2 s
FDelay	Relieving force during unlocking (force delay), only effective if TDelay is > 0	0,0...7,0 A	OFF
TLock	Door rectification time (time press close)	0,0...4,0 s	0,5 s
FLock	Pressing force during locking (force lock), only effective if TLock is > 0	0,0...7,0 A	2,0 A
FSlam	Accelerating function (force slam)	0...10	OFF
FWind	Obstacle detection optimized for exterior doors (force wind)	OFF OPEN CLOSE BOTH	OFF
Fo	Opening force (force open)	0...9	4
Fc	Closing force (force close)	0...9	4
Foh	Hold-open force (force open hold)	0...9	0
Fch	Interlocking force (force close hold) ⇒ automatically programs FLock and FDelay if these are 0	0,0...3,5 A	0
Ao	Opening angle of the door (angle open) If the opening angle is changed during the operating mode OPEN, the operating mode MANUAL needs to be selected for closing the door.	20...(190°) Rod dep.	95° *
Rod	Type of rod assembly (Rod)	Normal rods pushing fonction Sliding rods pulling fonction Sliding rods pushing fonction Wing mounting without rods pushing fonction without rods pushing fonction	STD-PH SLI-PL SLI-PH WIN-PH DIR-PH DIR-PL STD-PH *
Invers	Inverse application In the event of a power failure/error, the door leaf is opened by spring power from any position (unless it has not been locked). The position of the motor connector is reversed with regard to the standard drive unit. The electric lock/holding magnet must be connected in reverse order in comparison to the standard drive unit (see wiring diagram E4-0141-713_ECO).	OFF ON	OFF *
dAxis	Distance between rotation axis of the door hinges and the mounting level of the drive unit (distance Axis). dAxis is an approximate value. Depending on the installation situation, dAxis may have to be adapted.	-8...+25 cm Rod depending	0/+8 cm Rod dep. *
FTic	Closing force in closed position before Teach (only visible if Inverse is ON).	5...14 A	5 A

* Note:
A renewed setting-up procedure (Teach) is required.

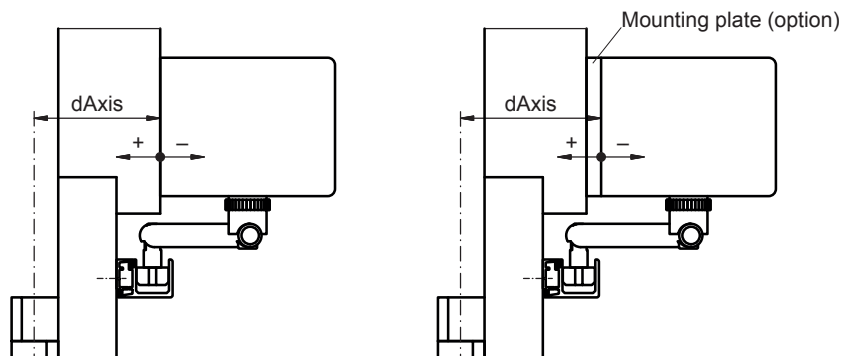

7.4.2 Configuration (CONFIG)

Parameter	Description	Setting range	Default
APuGo	Triggering angle Push&Go (angle push&go)	OFF, 2...10°	OFF
ASES	1) Suppression point Safety Element stop (angle safety element stop). If Ao is changed, ASES is automatically set to Ao.	45°...Ao	95° Ao depending (95°)
ASER	2) Suppression range of the safety element reversing (angle safety element reversing)	0...60°	0°
SeOpCo	Persistent opening (safety element open continue) After a Safety Element Stop during the opening procedure, the door shall continue its opening move (instead of closing), as soon as SES is activated.	OFF ON	OFF
SeOpTi	Waiting time till the drive unit closes even if SeOpCo = ON (safety element opening time), in the event that a fixed object blocks the door (only visible if SeOpCo = ON)	PERMAN 1...60 s	20 s
SESClo	Safety element Stop activated/deactivated during the closing motion (safety element stop closing)	ACTIVE INACTI	INACTI
EMY-IN	Configuration of the Emergency terminal (break contact) (emergency input)	CL-SPR (spring) STOP OPEN CL-MOT (motor)	CL-SPR
OExStp	Step-by-step control function (opening element step)	OFF OEI OEO KEY RADIO	OFF
RC 0.1	Parametrizable relay output 1 on optional PCB 1 (relay contact) (only visible if relay PCB 0 is plugged in)	CLOSED OPENING	CLOSED
RC 0.2	Parametrizable relay output 2 on optional PCB 1 (relay contact) (only visible if relay PCB 0 is plugged in)	OPEN CLOSING	OPEN
RC 0.3	Parametrizable relay output 3 on optional PCB 1 (relay contact) (only visible if relay PCB 0 is plugged in)	ERROR PSAUTO PSNIGHT	ERROR
RC 0.4	Parametrizable relay output 4 on optional PCB 1 (relay contact) (only visible if relay PCB 0 is plugged in)	PSEXIT PSOPEN	GONG
RC 1.1	Parametrizable relay output 1 on optional PCB 2 (relay contact) (only visible if relay PCB 1 is plugged in)	PSMANU GONG	OPENING
RC 1.2	Parametrizable relay output 2 on optional PCB 2 (relay contact) (only visible if relay PCB 1 is plugged in)	LOCKED SIX30S EMY_AL	CLOSING
RC 1.3	Parametrizable relay output 3 on optional PCB 2 (relay contact) (only visible if relay PCB 1 is plugged in)		PSAUTO
RC 1.4	Parametrizable relay output 4 on optional PCB 2 (relay contact) (only visible if relay PCB 1 is plugged in)		LOCKED
Unlock	Impulse/Permanent unlocking (impulse unlock)	IMPULS PERMAN	IMPULS
EL-Fb	Return signal of the electric lock (electric lock feed back) N.O. ⇒ Contact open if in the unlocked state (-), closed if in the locked state (+) N.C. ⇒ Contact open in the locked state (+), closed in the unlocked state (-) (+) and (-) indicate the status in the diagnostic menu.	OFF N.O. N.C.	OFF
LockAU	Operating mode AUTOMATIC locked (locked automat) (only visible if Unlock = Perman)	UNLOCK LOCK	UNLOCK
LockEX	Operating mode EXIT locked (locked exit) (only visible if Unlock = Perman)	UNLOCK LOCK	LOCK
LockMA	Operating mode MANUAL locked (locked manual) (only visible if Unlock = Perman)	UNLOCK LOCK	UNLOCK
LcdDir	Orientation of the display (LCD direction)	0...1	0
MovCon	Endurance test Open/Close (moving continuous)	OFF ON-FLT ON-PRM	OFF
OExMAN	Acceptance of opening commands after a manual door opening (only if APuGo = OFF) (opening element inside/outside manual)	OFF ON	OFF
PSKIze	Zero position of the program setting (operating mode); fixed program position that can only be changed by means of the terminals on the control unit (program selector key in the side cover inactive). Use for external program switch (only four terminals) or for controlling the program positions via the terminals on the control unit. (program selection terminal zero)	NO ACT PSOPEN PSHAND PSAUTO PSEXIT PSNIGT	NO ACT
SCBloc	Lock the program selector key in the side cover (side cover block) Toggle = Lock/unlock (press active program key during at least 5 seconds). Time = Lock (automatically after 5 minutes without any activation of the program keys), unlocking (press active program key during at least 5 seconds).	OFF TOGGLE TIME	OFF

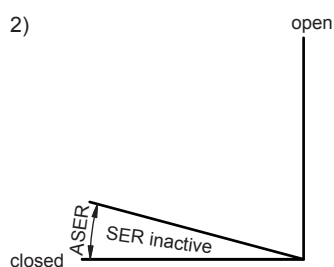
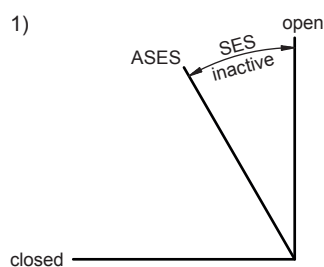

7.4.3 Installations with multiple door leaves (DOUBLE DOOR)

Parameter	Description	Setting range	Default
DubleD	Closing sequence role (Master/Slave) and interlock side (A/B)	OFF MastrA SlaveA MastrB SlaveB	OFF
AoSeq	Current delay angle for opening sequence control (Slave) (only visible if DupleD is active)	0..110°	20°
AcSeq	Current delay angle for closing sequence control (Master) (only visible if DupleD is active)	0..110°	20°
InterL	Interlock	OFF SideA SideB	OFF
ILAuto	Interlock mode Operating mode AUTOMATIC (only visible if InterL is active)	Inacti Active	Active
ILExit	Interlock mode Operating mode EXIT (only visible if InterL is active)	Inacti Active	Active
ILNigt	Interlock mode Operating mode NIGHT (only visible if InterL is active)	Inacti Active	Active

7.4.4 Menu navigation

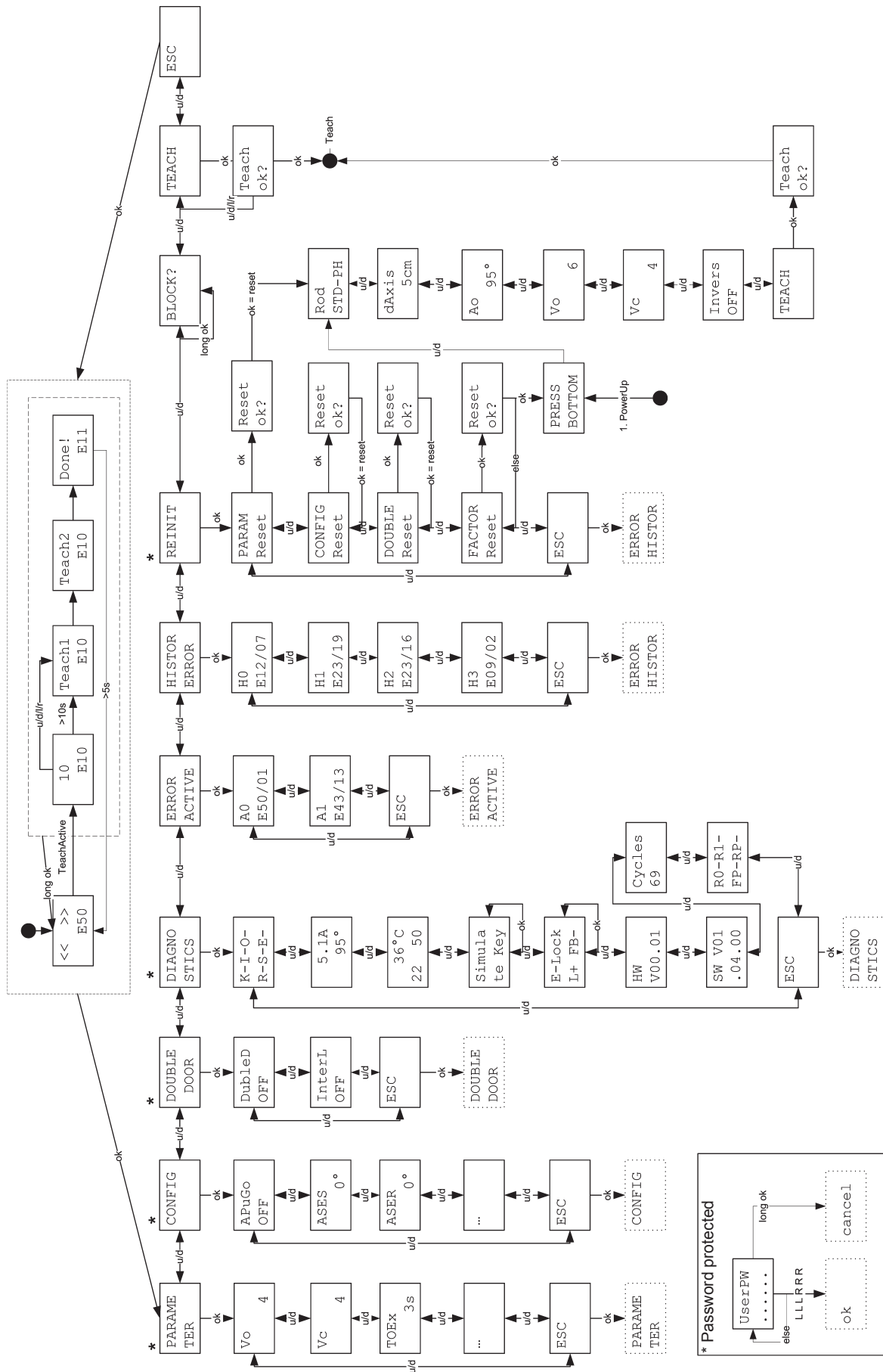

On the **1st level**, the following information is shown on the display:

1st display line:

The door position is represented by means of the arrows (><). Alternatively, the motion-relevant opening and safety signals are displayed. The double hash signs (##) indicate that the door is locked. In the open position the hold-open time is shown in the form of a countdown.

Display of the door position:

<REF?>	Waits for reference switch
< ?? >	Unknown
><	Closed
>##<	Closed and locked
<< >>	Opening
< >	Open
>> <<	Closing
==	Stopping



Display of the door control:

OEO	Opening element outside
OEI	Opening element inside
KEY	Opening element NIGHT
SES	Safety element Stop
SER	Safety element Reversing
SEF	Safety element Force (obstacle detection)
EMY	Emergency element
PUGO	Push-and-Go

2nd display line:

- at the bottom, left-hand side, the presently enabled operating mode is displayed (a frame around the symbol indicates the overriding operating mode).
- (m) means closing sequence - Master
- (s) means closing sequence - Slave
- (w) means interlock
- at the bottom, right-hand side, the presently active errors are displayed.

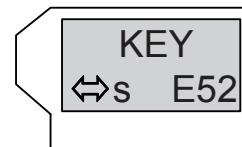
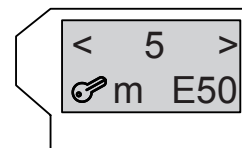

By means of OK you can switch over from the first to the second level.

For all the menus of the following list, exiting is possible by remaining on the OK key, or by means of the menu item ESC.

On the **2nd level**, the following menus are available:

PARAMETER

Setting the motional parameters

- A changed parameter value is shown by a flashing display.
Press OK in order to validate the change.

CONFIG

Setting the functionalities

- A changed parameter value is shown by a flashing display.
Press OK in order to validate the change.

DOUBLE DOOR

Setting the closing sequence and interlock function

- A changed parameter value is indicated by a flashing display.
In order to validate the change, OK must be pressed.

DIAGNOSTICS

Diagnostic tools

- K-I-O-R-S-E shows the inputs KEY (K), OEI (I), OEO (O), SER (R), SES (S), EMY (E). (+) stands for active, (-) for inactive.
 - 5.1A 95° shows the motor current and the door opening angle.
 - 37°C 25 65 indicates the presently measured temperature in the power electronics, completed by the minimum and the maximum values. OK causes the minimum and the maximum values to be reset.
 - Simulate Key: OK triggers a Key command.
 - E-Lock: L- shows the status of Lock (L). FB- shows the input EI-Fb. OK actuates the electric lock.
L+ resp. FB+ means locked. L- resp. FB- means unlocked.
 - HW Version: Version of the Logic PCB.
 - SW Version: Version of the Software.
 - Cycles: Total number of openings (this value is memorized).
- Optional PCBs ⇒ see chapter 13.8.

ERROR ACTIVE

Pending active errors

- The pending active errors are displayed in a list. This list is updated at the end and the latest additions appear during the next passage.
A0 indicates the latest error that has occurred.
- Exit the list by pressing OK.

HISTOR ERROR

Formerly active errors

- H0 indicates the latest error that has occurred.

REINIT

Carry out a re-initialization

- PARAM Reset sets all the motional parameters back to the default values (inclusive opening angle, rod assemblies, Invers and dAxis).
- CONFIG Reset sets all the configuration settings back to the default values.
- DOUBLE Reset sets all the closing sequence and interlock settings back to the default values.
- FACTOR Reset
The control unit is reset to the delivery configuration programmed by the manufacturer. This means that all the motional parameters, configurations, closing sequence and interlock settings are reinitialized with the default settings.
- Reset OK? is validated by means of OK and aborted by any other joystick movement.

BLOCK/UNBLOC

Lock/unlock the joystick

- **BLOCK**
Lock the joystick. For a temporary unlocking, press OK for more than 1 second. 60 seconds after the last joystick actuation, the joystick is automatically relocked.
- **UNBLOC**
Permanent unlocking of the joystick.

TEACH

Completely close the door leaf. Initiate a setting-up procedure (during the setting-up procedure the drive unit continues to beep).

- Teach OK? is validated by means of OK and aborted by any other joystick movement.
- The setting-up procedure can be canceled by means of the D-BEDIX (C-key).

Setting of the opening angle (Ao): During the first setting-up run, the drive unit moves to the open position (Ao) or up to the recommended open position stop piece, whichever event happens first, and the obtained result is memorized as opening angle. In the event of an excessively big difference between the actual opening angle and the displayed angle (in the diagnostic menu), this angle can be corrected (by means of dAxis). If the difference persists, the installation precision should be checked.

8 SERVICE

A regular service (maintenance/checking) is absolutely indispensable in order to guarantee a safe operation and long lifetime of the installation. The service must be carried out by a expert, **at least once a year**, according to the following checklist.

This checkup work basically refers to visual and functional checking destined to evaluate the integrity, the condition and the efficiency of the components and safety devices (checking of the different elements as far as these are included in the installation).



Warning:

To avoid jeopardizing the safety of persons, any defective safety elements may not be disconnected in order to continue the operation of the installation!



Attention:

In order to guarantee the availability of the installation, any elements showing signs of wear must be replaced as a preventive measure!



Note:

- Every service which has been carried out shall be entered into the control booklet!
- The following service description refers to the basic components. The options are described in detail in chapter "Options".



Attention:

If the fastening screw (A) of the lever arm is released, this screw must be secured upon tightening by means of Loctite 243, or else a new original screw needs to be inserted (see chapter: Spare parts).

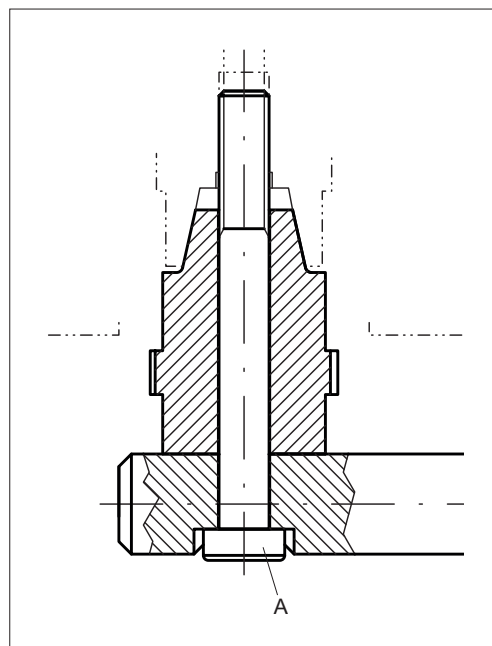

8.1 Service for pedestrian doors



Warning:

Electrocution hazard! Before working on any live elements, pull out the mains plug as well as any existing plug of the emergency battery respectively switch off the main installation switch!

	Check	Clean	Grease	Adjust
Installation				
General condition	x			
Free door movement (manually)	x			x
Door guides/guideway rails	x	x		x
Door sealing joints	x	x		x
Side panels/protection wings	x	x		
Coverings/hinge-type covers	x	x		
Tight fitting of screws and nuts	x			
Clean the installation ²	x	x		
Drive mechanism				
Drive mechanism	x	x		x
Transmission elements such as: toothed belt, flat belt, cables, rods or chains	x	x		x
Running carriages with carrying pulleys and counter-pressure pulleys	x	x		x
Carrier rails	x	x	x	
Open/Closed position	x			x
Control				
Electrical connections	x			
Functions related to installation	x			x
Program switch functions	x			
Emergency battery	x			
Emergency opening (pull out both power plugs of the ANTE's) ¹	x			
Control elements				
All the existing control elements such as: sensor, radar, key-operated switch, contact carpet, etc.	x	x		x
Safety elements				
Reversing/stopping mechanism	x	x		x
Door locking/manual unlocking mechanism	x	x	x	x
Mechanical emergency opening	x			x
Monitoring switch	x	x		x
Light barrier/Presence detector	x	x		x
Minimum escape way width ¹	x			x
Safety according EN16005				
Protections against impact				
Protections against crushing				
Protections against getting caught in				
Protections against shearing				
Protections against imprisoning				
Safety deficiencies must be communicated to the operator (in writing)!				
Miscellaneous				
Rating plate, glass identification sticker, etc. existing?				
Control booklet existing and completed?				

¹ Only for redundant drive mechanisms

² Gilgen cleans all the elements of the installation provided this is necessary for the function of the installation. A general cleaning of the installation is not planned.

8.2 Fundamental checking



Warning:
Switch the main installation switch off on the drive unit!

1. Dismount the covering of the drive mechanism.
2. Check all the cable connections.
3. Normal rods:
Separate the rod arm (B) from the rotating arm (A): Pull the spherical joint (C) apart.
4. Check the free running movement of the door leaf.
5. Check the bearings of the drive mechanism for increased noise level.
6. Normal rods:
Connect the rod arm (B) and the rotating arm (A): Snap in the spherical joint (C).
7. Mount the covering of the drive mechanism.

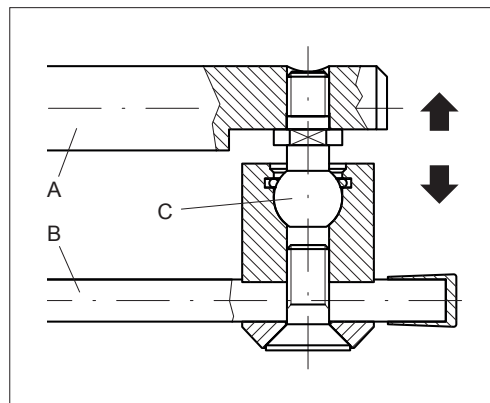

9 TROUBLESHOOTING



Warning:

Electrocution hazard! Before working on any live elements, pull out the mains plug respectively switch off the main installation switch!

If a malfunction occurs which might be detrimental to the safety of the users, and which cannot be eliminated without delay, the operator must be informed and if required the installation shall be taken out of operation. The installation must be repaired as soon as possible.



Note:

Every troubleshooting procedure which is carried out must be entered into the control booklet!

9.1 Malfunction with error-no.

The error is indicated on the display of the control unit.

Definition of the column "Reaction".

- A The drive unit deactivates itself during a certain period: Manual operating mode or stopping position.
- F Fatal error
- H Manual operating mode with re-starting attempt
- W Warning

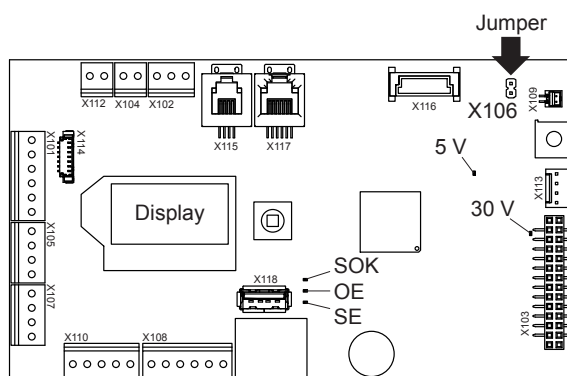

9.1.1 Drive mechanism

No.	Description	Cause	Elimination	Checking time	Reaction	
E1	03 Encoder	Channels A + B lost	Check the encoder connection. Check the motor cable. The sense of rotation of the motor is not in compliance with the rod assembly. The door is blocked. Check if a jumper has been inserted on X106.	During run.	H	
		Short-circuit A + B				
		Dysfunctions				
		06		Motor cable uncorrect plugged in	Prior to start-up.	H
		07		No channel A		
		08		No channel B		
		09		No channel A + B		
10	Short-circuit A + B					
E2	01 Motor current	Current too high	Check the motor cable. Check if a jumper has been inserted on X106.	Prior to start-up.	H	
		02				Current too low Jumper missing
E3	01 Cushioning	Test failed once	Switch the drive unit to the MANUAL operating mode and carefully check if the door closes in a cushioned manner. If not: replace the hardware. If yes: check/correct the friction of the door leaf and the pre-stressing of the closing spring.	Prior to the closing motion, after start-up, and subsequently every 24 h.	W F Drive unit is functioning. Buzzer activf.	
		02				Test failed twice. Damping defective or opening beyond the peak of the cardio-ids curve.
E4	01 Reference switch	Detected in the open position.	Check the connection and the switching point of the reference switch. The reference switch must be activated in the closed position (switching contact open).	Open position.	F	
		02		Not detected in the closed position.	Prior to the first setting-up run.	A
		03		Not detected in open position.		
E5	00 Power limitation.	Overload of the control. the maximum power is restricted.	Check/correct the friction of the door leaf and the pre-stressing of the closing spring.	Permanent.	A	

9.1.2 Operating

No.	Description	Cause	Elimination	Checking time	Reaction
E10	01 Fullteach required	Parameter Ao, Rod, Invers or dAxis changed.	Carry out a teach.	Upon changing the drive unit configuration.	H
		Minimum opening angle has not been reached.	Check the locking/electric lock	During Teach.	H
E11	01 Halfteach required (Opening)	Parameter Vo changed.	Carry out a complete and unhindered opening cycle.	Upon changing the motion parameters.	W
	02 Halfteach required (Closing)	Parameter Vc or FSlam changed.	Carry out a complete and unhindered closing cycle.		
E12	03 Excessively high current consumption during Teach in the open position (> 5 A)	Drive unit pushes against the open position stop piece or an obstacle. The spring tension is possibly too high.	Reduce the opening angle Ao. Reduce the spring tension.	Open position Teach 3 (E11).	F
E14	01 Locking/electric lock	The door leaf got caught in the locking/electric lock.	Check the function of the locking/electric lock.	When opening from a closed position.	H
		The inverted operation has no locking, or the interlocking force Fch has not been programmed.	Program/increase the interlocking force Fch.	At the end of the teach-in procedure.	W
E15	01 Obstacle in opening direction	Too many successive obstacles have occurred.	Examine the installation. Remove the obstacle. Move the door leaf to the target position.	Permanent.	H, A Restart after 60 s.
	02 Obstacle in closing direction				
E16	01 Temperature	Temperature on output level has reached 81 °C.	Respect the application limits.	Permanent.	A Drive unit functions with reduced power. A Drive unit has stopped.
	02	Temperature on output level has reached 91 °C.			

9.1.3 Safety elements

No.	Description	Cause	Elimination	Checking time	Reaction
E20	01 SER Test	SER Test signal unsuccessful.	SER short-circuit to the earth. Check the cabling of the sensor or the jumper.	Prior to closing.	A
		SER too slow.	SER reacts too slowly. Check the cabling of the sensor. Check for polarity reversal/test signal.		
E21	01 SES Test	SES Test signal unsuccessful.	SES short-circuit to the earth. Check the cabling of the sensor or the jumper.	Prior to opening.	A
		SES too slow.	SES reacts too slowly. Check the cabling of the sensor. Check for polarity reversal/test signal.		
E22	01 EMY Test	EMY input on 24 V.	Check the jumper EMY. Check the cabling of EMY.	Permanent.	H

9.1.4 Feeding

No.	Description	Cause	Elimination	Checking time	Reaction
E30	01 30 V Error	30 V too low.	Mains failure, overload motor. Check the feed-in. Replace the hardware.	Permanent.	A
		30 V too high.			
		Error upon switching-on.			
E31	01 24 V General	Error upon switching-on.	Overload, short-circuit of the 24 V inputs (without electric lock, safety elements).	Permanent.	A Restart after 10 s.
		Over- resp. under-voltage.			
E32	01 24 V Safety	Over- resp. under-voltage.	Overload, short-circuit safety Elements.		
E33	01 24 V E-Lock	Error: Over-resp. under-voltage.	Overload, short-circuit electric lock.		
		Premonition: Over-resp. under-voltage.			
E34	01 24 V CAN	Over-resp. under-voltage.	Overload, short-circuit external power supply CAN.		

9.1.5 System

No.	Description	Cause	Elimination	Checking time	Reaction
E50	01...99	System error	Unexpected hardware or software event.	Permanent.	W or H or F
E51	01...99				
E52	01...99				

9.1.6 Options

No.	Description	Cause	Elimination	Checking time	Reaction	
60	00	Option PCB has been removed, its address changed or become defective.	Check if the option is provided. If defective: Replace or remove from the configuration. Note: Deleting of error 60 ⇒ see chapter 13.8.1.	Permanent.	W	
	10			Relay PCB 1	Permanent.	W
	20			Radio PCB	Permanent.	W
	30			Fire-protection	Permanent.	A

9.1.7 Closing sequence / Interlock function

No.	Description	Cause	Elimination	Checking time	Reaction	
70	xx	CAN bus setting	CAN address xx existing twice.	Correctly define the role of the closing sequence or the interlock function.	Permanent.	W
E71	01	CAN connection.	No CAN connection.	Plug in, check or replace the CAN cable. Check if all the CAN participants are switched on.	Permanent.	W

9.2 Malfunction without error-no.

In some cases, it will be technically impossible to display an "irregular functioning" of the installation by a definite error number. An alleged error may by all means also be due to "correct" causes. For this reason the list shown hereafter has been established, which contains the probable or already encountered irregular functioning, their possible causes as well as the corrective action (error elimination) to be taken.

Erroneous behavior	Analysis	Possible causes	Remedy
Drive unit fails to react • No automatic opening. • No reaction on the control elements (side cover/ D-Bedix).	<ul style="list-style-type: none"> • The program selection keys in the side cover are not lighted. • LED 5 V (green) on the control is not lighted. 	Power supply voltage is missing.	<ul style="list-style-type: none"> • Switch on the main installation switch in the side cover. • Measure the mains supply voltage, check its cabling and eliminate any detected deficiencies. • Should the two above-mentioned measures not be successful, the control unit needs to be replaced.
Drive unit fails to open.	<ul style="list-style-type: none"> • LED SE (safety element, yellow) is lit. • Determine the active safety element via the diagnostic level. 	One or more safety elements are active or incorrectly cabled.	<ul style="list-style-type: none"> • Remove the obstacle. • Check the cabling between the safety element and the control unit, and eliminate any detected deficiencies. • Replace the safety element.
	<ul style="list-style-type: none"> • LED SE (safety element, yellow) is not lighted. • LED OE (opening command, blue) reacts to the opening element. • Determine the opening element via the diagnostic level. 	Depending on the enabled operating mode, the opening commands (inside/outside, etc.) are ignored.	<ul style="list-style-type: none"> • Change the operating mode. • Correct the cabling of the opening elements.
	<ul style="list-style-type: none"> • LED SE (safety element, yellow) is not lighted. • LED OE (opening command, blue) is not lighted despite the active opening element. 	The opening command is not evaluated.	<ul style="list-style-type: none"> • Check the cabling between the opening element and the control unit and eliminate any detected deficiencies. • Replace the opening element.
Drive unit fails to close.	<ul style="list-style-type: none"> • LED SE (safety element, yellow) is lit. 	One or more safety elements are active or incorrectly cabled.	<ul style="list-style-type: none"> • Remove the obstacle. • Check the cabling between the safety element and the control unit and eliminate any detected deficiencies. • Replace the safety element.
	<ul style="list-style-type: none"> • LED SE (safety element, yellow) is not lighted. • LED OE (opening command, blue) is lit. 	An opening command is pending.	<ul style="list-style-type: none"> • Check the cabling between the opening element and the control unit and eliminate any detected deficiencies. • Replace the opening element.
	<ul style="list-style-type: none"> • Check the operating mode. 	The operating mode OPEN is active.	<ul style="list-style-type: none"> • Change the operating mode.
The operating mode cannot be changed.	<ul style="list-style-type: none"> • The program selection keys in the side cover are not lighted. 	The ribbon cable is not plugged in correctly, or not plugged in at all.	<ul style="list-style-type: none"> • Check the ribbon cable and eliminate any detected deficiencies.
	<ul style="list-style-type: none"> • The operating mode symbol on the display is underlined. 	The operating mode is overridden via connection terminal X110.	<ul style="list-style-type: none"> • Change the operating mode by means of the external program selector switch. • Correct the cabling of the external program selector switch.
Prior to commissioning: During manual opening, the door leaf encounters an important resistance and closes at high speed.		The motor connector plug is not correctly connected.	<ul style="list-style-type: none"> • Plug the motor connector plug into the correct socket, in accordance with the application (pulling/pushing function) (see chapter 4.1; Default setting = pushing function).

9.3 Software update via USB

A software update of the ETS 73 control unit can be easily and rapidly achieved by means of an USB memory stick.



Note:

Not all the USB memory sticks can be used. We thus recommend a previous testing of their function together with the ETS 73.

9.3.1 Preparation

The USB stick must contain a folder FD20.

The file name of the application must specify FD20.

The name of the file extension must be **gds**.

- ⇒ The stick shall only contain one single FD20 folder.
- ⇒ There must be only one single file in the FD20 folder.

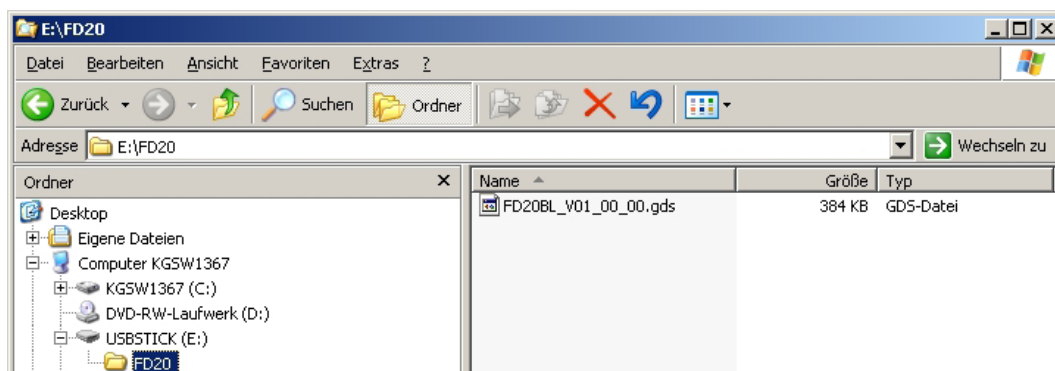

9.3.2 Procedure

1. Switch off the main installation switch on the ETS 73.
2. Plug the USB stick into the control unit ⇒ socket X118.
3. Switch on the main installations switch on the ETS 73.
4. The software download takes approx. 1 minute ⇒ Watch the LED display on the control unit.

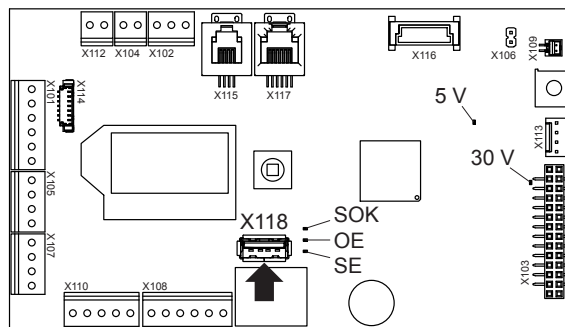

9.3.3. LED display on the control

The display of the functions is ensured via three LEDs on the control PCB:

SOK	Green	USB-Loader started
OE	Blue	Activity in progress (delete/write memory)
SOK + OE	Green/Blue	Download completed ⇒ remove the stick
SE	Yellow	Error

9.3.4 Possible errors

- Incorrectly formatted USB stick
⇒ this stick must be FAT or FAT 32 formatted (File Allocation Table from Microsoft).
- Several drives existing on the USB stick
⇒ only one drive is legible.
- Invalid file
⇒ Not encrypted, damaged, FD20 missing in the file name, **gds** missing in the file extension.

10 SHUT-DOWN

No particular measures need to be taken for de-commissioning the installation.

If the swing door drive mechanism will not be used during at least 1 month, it is recommended to pull out the mains plug.

For taking the installation back into operation, all you have to do is to plug in the mains cable and select the operating mode.



Attention:

If the installation is re-commissioned at low temperatures, it must be switched on 1...2 hours prior to the actual setting-up procedure (so that the operating temperature can be reached).

11 DISPOSAL OF THE INSTALLATION

An ecologically acceptable disposal of the installation is ensured if the different materials are separated and recycled. No particular measures are required for the protection of the environment. However, the relevant legal prescriptions applicable for the installation site have to be complied with!

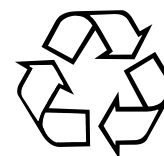

12 SPARE PARTS

Article No.	Designation	Remark
0548-116	Drive module	
0548-204	Switch support complete	
0548-107	Fixing set	
0548-358	Mounting plate	Option
0548-360	Mounting plate Mod.	Option
0548-106	Open stop piece integrated into the drive unit	Option
0548-118	Control unit complete	
0548-113	Encoder cable, reference switch cable, screws	
0548-215	Relay PCB	Option
0548-216	Radio PCB	Option
0635-142	D-BEDIX	Option
0548-133	Service D-BEDIX	for fitter
0548-400	Drive mechanism covering (incl. 0548-143)	Aluminium
0548-143	Covering accessories	Aluminium
0548-120	Drive mechanism covering (incl. 0548-115)	Stainless steel
0548-115	Covering accessories	Stainless steel
0548-103	Side cover complete incl. main switch and program selector	
0548-144	Side cover	
0548-209	Flexible cable routing	Option
0548-104	Normal rods	
0548-104/01	Normal rods KTL	
0548-134	Sliding rods	
0548-105/02	Sliding rods for leaf mounting incl. sliding rail 830 mm	
0548-114	Clamping piece standard (incl. screw)	
0548-124	Clamping piece -13 mm (incl. screw)	Option
0548-125	Clamping piece +20 mm (incl. screw)	Option
0548-126	Clamping piece +50 mm (incl. screw)	Option
4099-127	Tuflok screw -10 mm (for clamping piece -13 mm)	Option
4099-282	Tuflok screw standard	Option
4099-286	Tuflok screw +20 mm	Option
4099-290	Tuflok screw +50 mm	Option
0547-232	Connection plate for wooden door leaf normal rods	Option
0548-222	Expansion element complete (2 pieces) for sliding rail	
0548-223	Glider for sliding rods	
0548-380	Covering caps (2 pieces) for sliding rail	
0548-398	Sliding bolt 14 mm for sliding rods	
0547-376	Sliding bolt 38 mm for sliding rods	

13 OPTIONS

13.1 D-BEDIX

The different operating modes can be directly enabled by means of the D-BEDIX. In addition, it provides easy programming of the most important door settings.

The operating modes, menu settings as well as possible errors are displayed in a clearly arranged synopsis.

The D-BEDIX is connected to the control unit ETS 73 via a screened two-core connection cable (e.g. U72M or EIB-Y(St)Y, max. length 50 m).

Only one D-BEDIX can be connected per door installation.

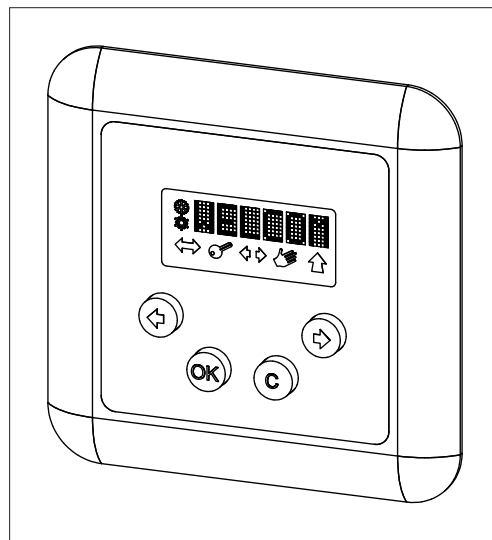

13.1.1 Keys



- C-key (Cancel)
- Exit the menu
 - Invalidate entry.



- OK-key
- Confirm the selection
 - Confirm the entry.



- Arrow keys
- Navigate within the menus



- Short simultaneous actuation of both keys = acces to the menu level.

13.1.2 Symbols



- Operating mode symbols
- Show the possible operating modes (see chapter: Operating modes).



- Selection frame (active and preselected operating mode)
- Shows what has been presently selected.



- Selection frame (active operating mode)
- Shows what has been presently selected but is still inhibited. A control element with higher priority (e.g. key-operated switch) determines the operating mode.



- Bar (preselected operating mode)
- Shows the preselected operating mode.

13.1.3 Operating modes

With the D-BEDIX, the following operating modes can be selected by means of the corresponding symbols:



AUTOMATIC

Automatic operation. The installation can be locked.



NIGHT

The installation is locked¹. As opening commands, only the key-operated impulse switch is accepted.

The delayed switchover to the operating mode NIGHT can be activated by means of parameter TdNigt. Function: If the program selector switch is changed to the operating mode NIGHT from any random operating mode, the internal radar will still remain active during the programmed time TdNigt (EXIT).



OPEN

The installation is opened and remains in the open position.



MANUAL

The installation stops. The swing door leaf is released and can be manually opened and closed.



EXIT

One-way traffic from inside towards the outside.

The installation is locked² (shop closing switching mode).

¹ Provided that the locking mechanism (optional) is installed.

² Each operating mode can be locked (this is configurable).

13.1.4 Display of the door position

The following door positions are represented on the D-BEDIX display:

<REF?>	Waits for reference switch
< ?? >	Unknown
><	Closed
>##<	Closed and locked
<< >>	Opening
< >	Open
>> <<	Closing
==	Stopping

13.1.5 Menu level

Short and simultaneous actuation of both arrow keys (=access to the menu level).
 Select the desired menu item by means of the arrow key.
 Confirm by means of the OK key.

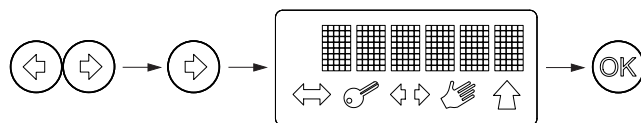

Display	Description
PARAMETER	Setting the motional parameters *
CONFIG	Setting the functionalities *
DOUBLE DOOR	Setting the closing sequence and interlock function *
DIAGNOSTICS	Diagnostic tool
ERROR ACTIVE	Active pending errors
ERROR HISTORY	Formerly active errors
REINIT	Carry out a re-initialization *
BLOCK/UNBLOC	Lock/unlock keys
TEACH	Initiate a setting-up procedure ⇒ make sure that the door leaf is completely closed.

* password protected



Note:
 The detailed settings are described in chapter 7.4.

13.1.6 Setting examples

Changing the operating mode

Select the desired symbol by means of the arrow key (symbol starts flashing).
 Confirm with the OK key (frame/bar switch over).

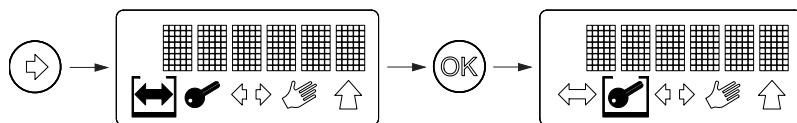

Preselecting the operating mode

An overriding switch is active and determines the operating mode (only the selection frame is visible, the bar underlines the preselected operating mode). Now you can select the operating mode you want to be active upon cancellation of the overriding switch:
 Select the desired symbol by means of the arrow key (symbol starts flashing).
 Confirm with the OK key (bar switches over).

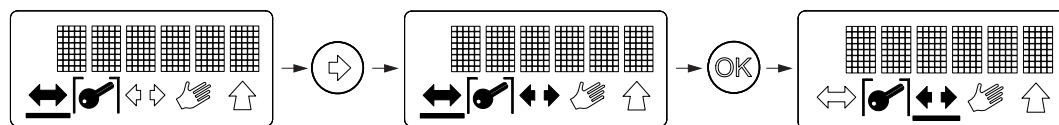

Enabling the keylock

Short simultaneous actuation of both arrow keys (= access to the menu level).
 By means of the arrow key, select BLOCK.
 Confirm with the C-key and the right-hand arrow key.

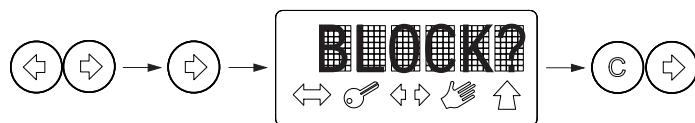

Temporarily disabling the keylock (60 s)

Short simultaneous actuation of the C-key and the right-hand arrow key.



Disabling the keylock

Short simultaneous actuation of the C-key and the right-hand arrow key.
 Short simultaneous actuation of the arrow keys (= access to the menu level).
 By means of the arrow key, select UNBLOC.
 Confirm with the C-key and the right-hand arrow key.

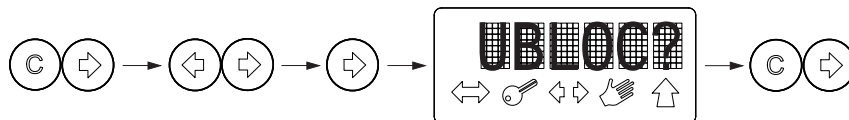

Parameters (hold-open timeday)

Short simultaneous actuation of the arrow keys (= access to the menu level).

By means of the arrow key, select TOEx.

Confirm with the OK key.

By means of the arrow key, change the value.

Confirm with the OK key.

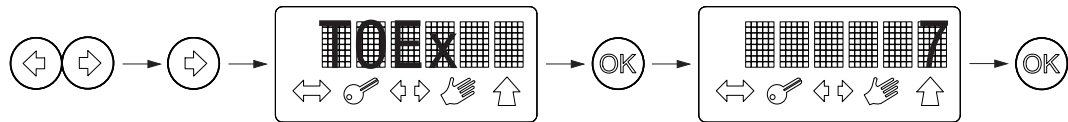
**Teach**

Completely close the door leaf.

Short simultaneous actuation of the arrow keys (= access to the menu level).

By means of the arrow key, select Teach.

Confirm with the OK key.

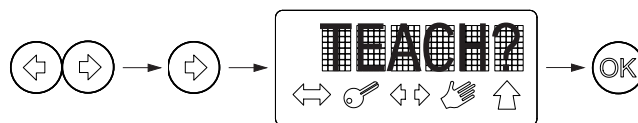
**13.1.7 Error display**

In the event of an error, the display shows (alternating with the door position status) the presently active error number (e.g. E20/01).

Error list: see chapter Troubleshooting.

This sequence will be repeated until the error has been eliminated.

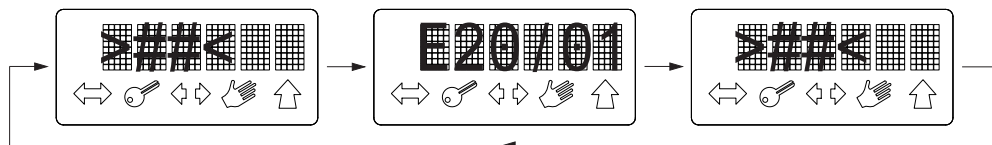

13.2 KOMBI-D-BEDIX

In addition to the functions of the D-BEDIX, the KOMBI-D-BEDIX contains a key-operated switch (round or profile cylinder) with the following function:

Lockout of the KOMBI-D-BEDIX against unauthorized use.







Free

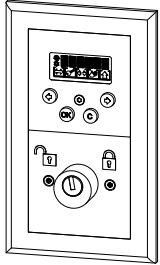
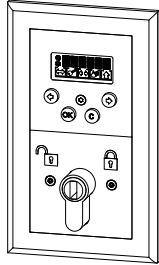

Locked



If this lockout is enabled, all the keys are shortly lit (as a confirmation of the lockout).

 <p>Round cylinder</p>	 <p>Profile cylinder</p>		
<p>Cylinder: to be supplied by customers</p> <table border="1"> <tr> <td data-bbox="911 622 1157 1155">  <p>0635-148/04 KABA 1514 SEA 1.043.0 DOM 2222H ix5 Driver with 8 adjus. possibilities KESO 11.014.045 KESO 21.014.045 KESO 31.014.045 Adjustable beard E201</p> </td> <td data-bbox="1157 622 1402 1155">  <p>0635-148/02 KESO 21.214.040 Adjustable beard E200 DOM 333 ix-5 Driver with 8 adjusting possibilities BKS 8900 N BL 31 BKS 3101 N BL 31 BKS 3301 N BL 31 ZEISS IKON 0040 ZEISS IKON 5040 ZEISS IKON 5044 ZEISS IKON 6044 ZEISS IKON 7044</p> </td> </tr> </table>		 <p>0635-148/04 KABA 1514 SEA 1.043.0 DOM 2222H ix5 Driver with 8 adjus. possibilities KESO 11.014.045 KESO 21.014.045 KESO 31.014.045 Adjustable beard E201</p>	 <p>0635-148/02 KESO 21.214.040 Adjustable beard E200 DOM 333 ix-5 Driver with 8 adjusting possibilities BKS 8900 N BL 31 BKS 3101 N BL 31 BKS 3301 N BL 31 ZEISS IKON 0040 ZEISS IKON 5040 ZEISS IKON 5044 ZEISS IKON 6044 ZEISS IKON 7044</p>
 <p>0635-148/04 KABA 1514 SEA 1.043.0 DOM 2222H ix5 Driver with 8 adjus. possibilities KESO 11.014.045 KESO 21.014.045 KESO 31.014.045 Adjustable beard E201</p>	 <p>0635-148/02 KESO 21.214.040 Adjustable beard E200 DOM 333 ix-5 Driver with 8 adjusting possibilities BKS 8900 N BL 31 BKS 3101 N BL 31 BKS 3301 N BL 31 ZEISS IKON 0040 ZEISS IKON 5040 ZEISS IKON 5044 ZEISS IKON 6044 ZEISS IKON 7044</p>		

13.3 Open position stop piece integrated in the drive unit



Attention:

It is recommended that a stop piece be mounted by the customer. This stop piece prevents the door leaf from being damaged in the manual operating mode. As an option, an open position stop piece can be integrated into the drive unit itself.

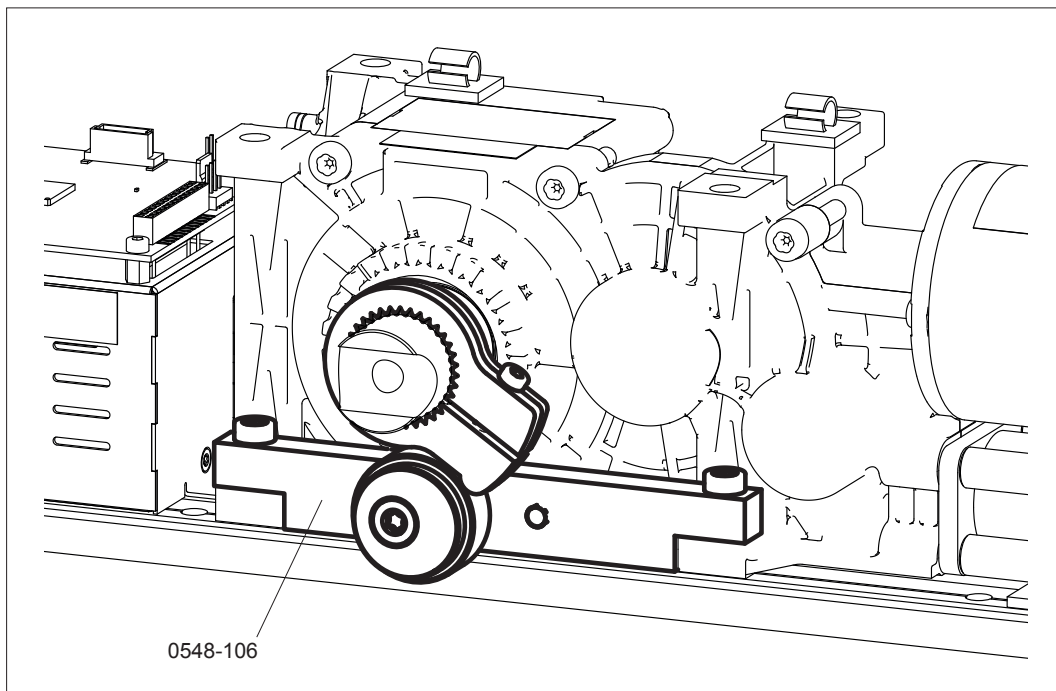

13.4 Connection plate for wooden door leaf (normal rods)

The connection plate is mounted below the door connection angle of the normal rod assembly and screwed down by means of countersunk chipboard screws 5 x 30.

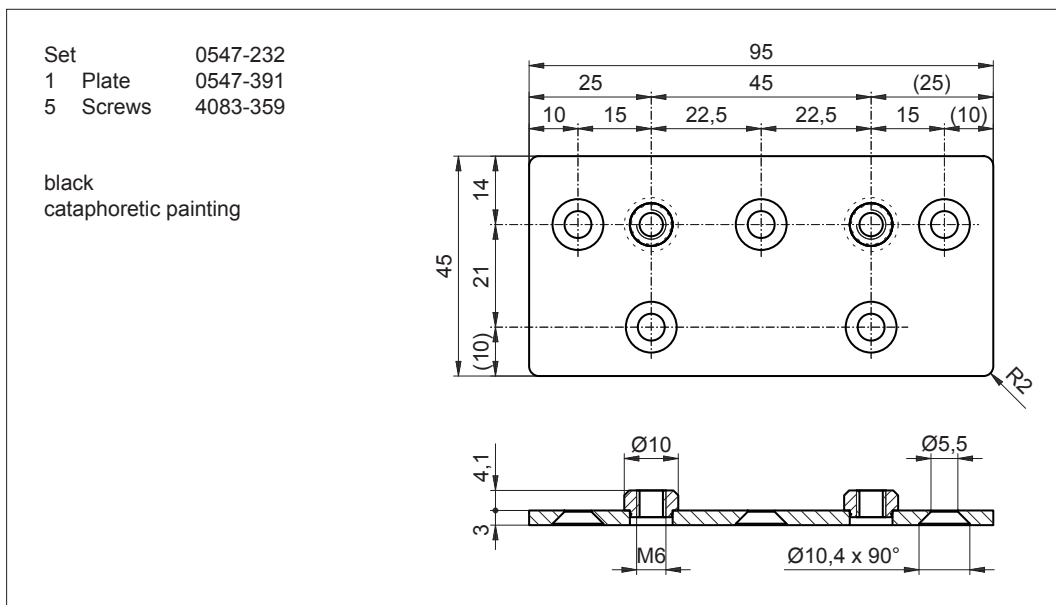

13.5 Mounting plate

In cases where the fastening holes provided in the chassis profile of the ETS 73 cannot be used, the mounting plate 0548-358 can be used as an alternative.



Attention:
The mounting measures according to chapter 4 must be verified and complied with!

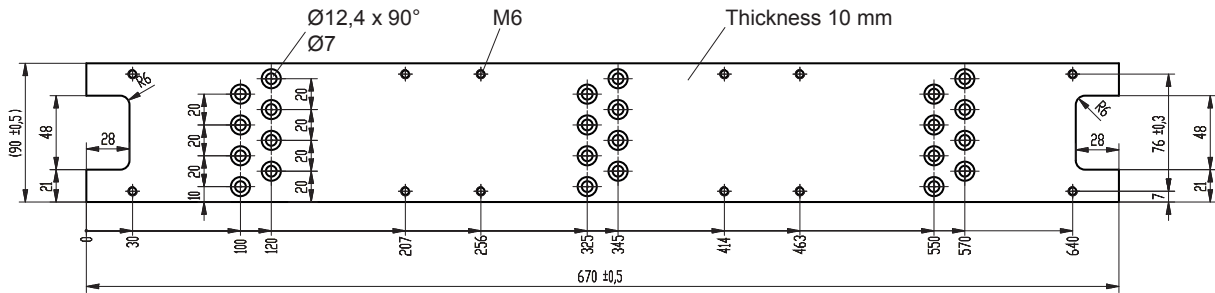

13.6 Mounting plate ETS 73 Mod

The mounting plate 0548-360 can be used in cases where an existing FDC drive unit needs to be replaced by an ETS 73 drive unit and where the existing fastening holes of the FDC-mounting plate have to be reused.



Attention:
The mounting measures according to chapter 4 must be verified and complied with!

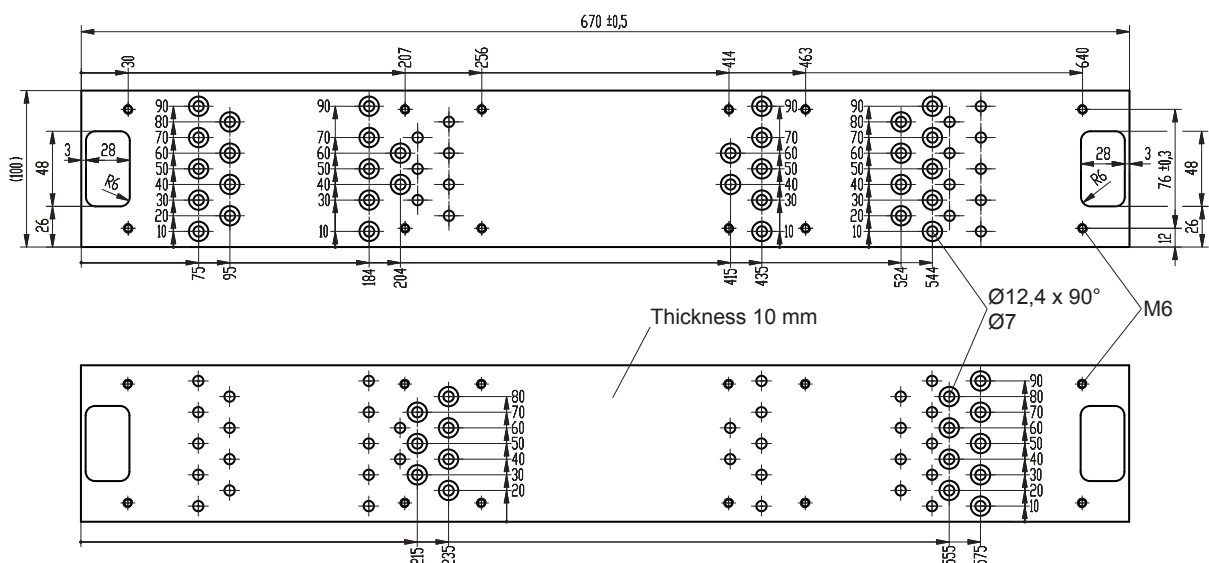

13.7 Continuous covering

For bi-parting installations, the two drive units can be optically connected by inserting an intermediate covering piece.

- | | | |
|--|-------------|----|
| Set with drive mechanism covering 1,9 m | 0548-214 | or |
| Set with drive mechanism covering 1,2 m | 0548-220 | |
| 1 Drive mechanism covering Aluminium natural anodised E6/EV1 | 0548-304/01 | |
| 1 Intermediate profile Aluminium untreated | 0548-414/60 | |
| 1 Fixing set | 0548-214/90 | |

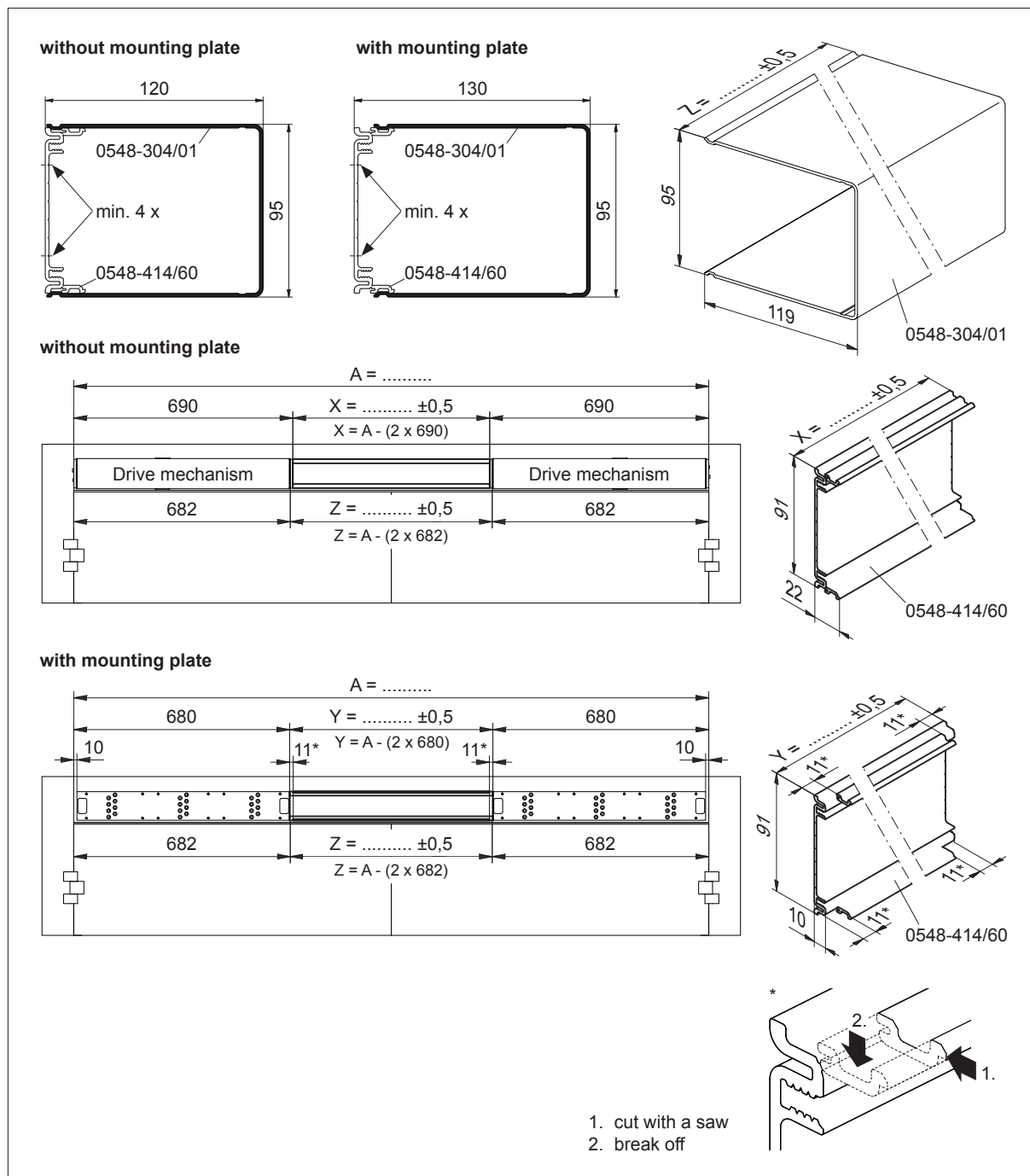

13.8 Optional PCBs

All the optional PCBs are plugged into the control unit via a universal connector. A maximum number of two optional PCBs can be combined.



Attention:

All the four optional PCBs must only be plugged into/removed from the control unit after the drive unit has been disconnected from the power supply source!

13.8.1 Relay PCB

The relay PCB (blue) offers four outputs to be freely used by the customer.

Commissioning:

- Addressing of the relay PCB by means of DIP-Switch:
DIP-Switch Addr0 or Addr1
- Switch-on the main installation switch on the drive unit ⇒ the relay PCB is automatically identified.

The identified relay PCB is displayed as follows in the diagnostic menu:

R0 Addr0
R1 Addr1
FP Fire protection PCB
RP Radio PCB
+ identified and ready for operation
- neither identified nor registered
e defective or error
x removed

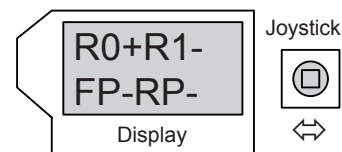
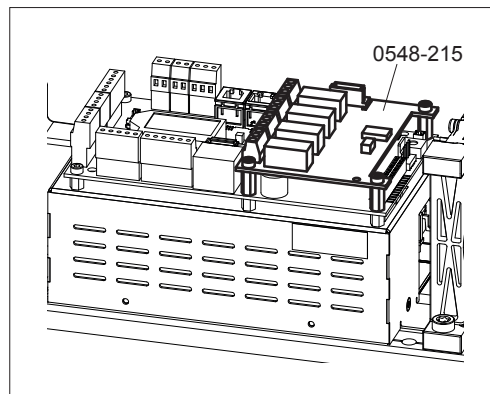

Joystick



- Enabling of the desired function per relay: under Settings ⇒ Configuration RC0.1 up to RC0.4 (for Addr 0) and RC1.1 up to RC1.4 (for Addr 1).

Remove the relay PCB:

- Switch-off the main installation switch on the drive unit.
- Remove the relay PCB.
- Switch-on the main installation switch on the drive unit.
Display: E60/00 ⇒ Addr0
E60/10 ⇒ Addr1

- Select menu: Diagnostics
R0-R1-...
R0xR1-...
R0-R1x...
R0xR1x...

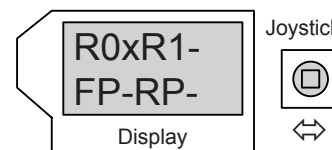

Joystick



- In the rest position, press in the joystick: Reset OK? ⇒ The relay PCB is deleted from the configuration.

13.8.2 Radio PCB

A radio control PCB can be plugged into the control of the drive unit. Using a hand-held radio transmitter, this PCB can be programmed with a code, upon which the drive unit can be controlled via the hand-held radio transmitter.

In cases where several hand-held radio transmitters shall be used for controlling the same drive unit, all the transmitters need to be programmed with the same code (which is transmitted from the standard transmitter to all the additional transmitters).

On the other hand, several drive units can be simultaneously controlled by one single button.

Teaching the hand-held radio transmitter:

1. Keep the button (A) on the radio control PCB depressed (at least during 3 seconds) until the red LED (B) flashes at regular intervals.
2. Maintain the desired button of the hand-held radio transmitter depressed until the red LED (B) on the radio-control PCB lights up for about 2 seconds.
3. As soon as the red LED (B) is extinguished, this means that the code of the hand-held transmitter button has been memorized in the radio control PCB.

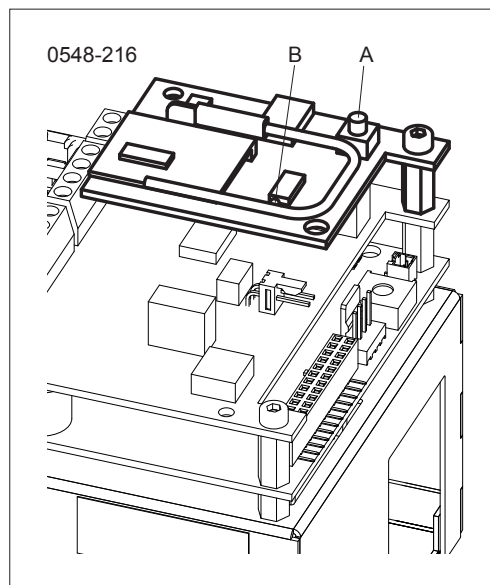

13.9 LZR-FLATSCAN

In the event of swing doors, the FLATSCAN is mounted on the moving leaf, on the upper leaf corners (as close as possible to the secondary closing edge). The FLATSCAN can only be used in pairs! Master and Slave are connected among each other.

If a door radar is mounted directly above the FLATSCAN, it is compulsory to mount the weather canopy (for screening against radar microwaves).

Lintel mounting
Normal rods pushing

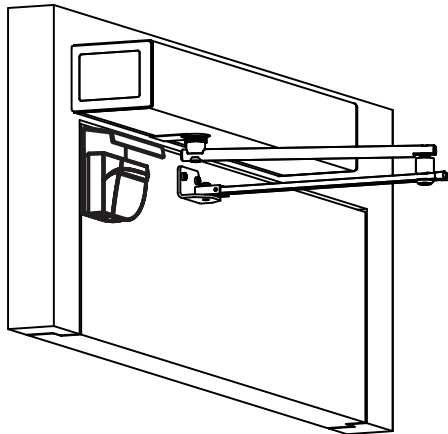

Lintel mounting
Sliding rods pushing

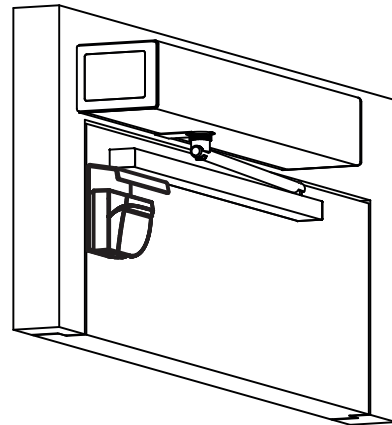

Lintel mounting
Sliding rods pulling

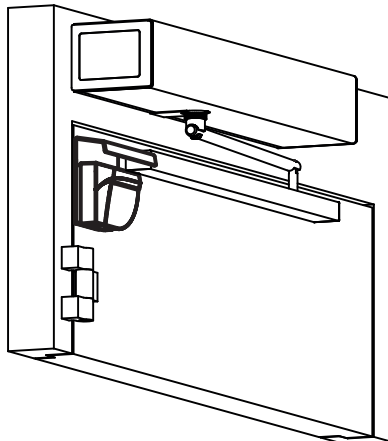

Leaf mounting
Sliding rods pushing

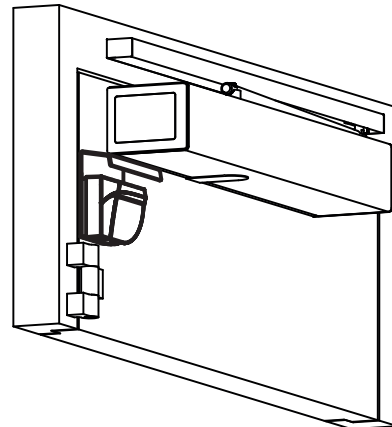

Mounting:
see mounting instructions LZR-FLATSCAN

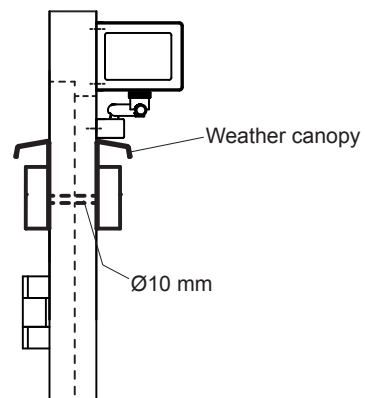

14 APPENDIX

The following document is added as an appendix to this instructions:

Wiring diagram	E4-0141-713_ECO
Wiring diagram Relay PCB	E4-0141-715_ECO
Wiring diagram motorised locks	E4-0142-180_ECO



ECO

ECO Schulte GmbH & Co. KG
 Iserlohner Landstrasse 89
 D-58706 Menden

SWISSDOOR
 DØRTEKNIK FOR PROFESSIONELLE

Danish Seller:

Swissdoor ApS
 Stenhuggervej 2
 DK-5471 Soendersoe
 Tlf.: +45 86 28 00 00
 mail@swissdoor.dk
 www.swissdoor.dk

ETS 73 and ETS 64-R
 Drive mechanism for swing door

Notes description

Index of contents

- Sheet 1 = Control PCB
- Sheet 2 = 1-winged; Occupation of terminals
- Sheet 3 = Mounting variants/Motor connection:
 DIN right/DIN left (standard/inversed)
- Sheet 4 = } Double door: - Closing sequence Master
- Sheet 5 = } - Closing sequence Slave
- Sheet 6 = } Interl. syst.: - Side A
- Sheet 7 = } - Side B

Diagram drawn; door is closed; mains off
⊛ If element is missing, put a jumper.
⌚ Total load +24V: Max. 2A

Stückliste		a	12.5.16/13.11.13	al	e	Gezeichnet	07.03.12	al	Ursprung:	WIRING DIAGRAM ETS 73 and ETS 64-R Drive mechanism for swing door	Anlage:	Blatt-Nr. 0 Anz.Blatt 7	E4-0141-713c_ECO
Ohne sep.	<input checked="" type="checkbox"/>	b	13*029/05.06.15	al	f	Geprüft			Ersatz für:				
Sep. gl. Nr.	<input type="checkbox"/>	c	13*154/09.10.15	al	g								
Sep. and. Nr.	<input type="checkbox"/>	d			h	Freigegeben							

ETS 73, ETS 64-R 0548-118

Control PCB

- ① LC-Display
- ② Joystick
- ③ Buzzer
- ④ Processor
- ⑤ Potentiometer for door closing in manual operation
- ⑥ Status LED

X103 Plug-in connection to Power supply unit

X109 Connection to Reference switch

X113 Connection to Encoder

X114 Connection of program selectors at side cover

X115 Serial port

X116 Plug-in for options

X117 CAN

X118 USB/Service

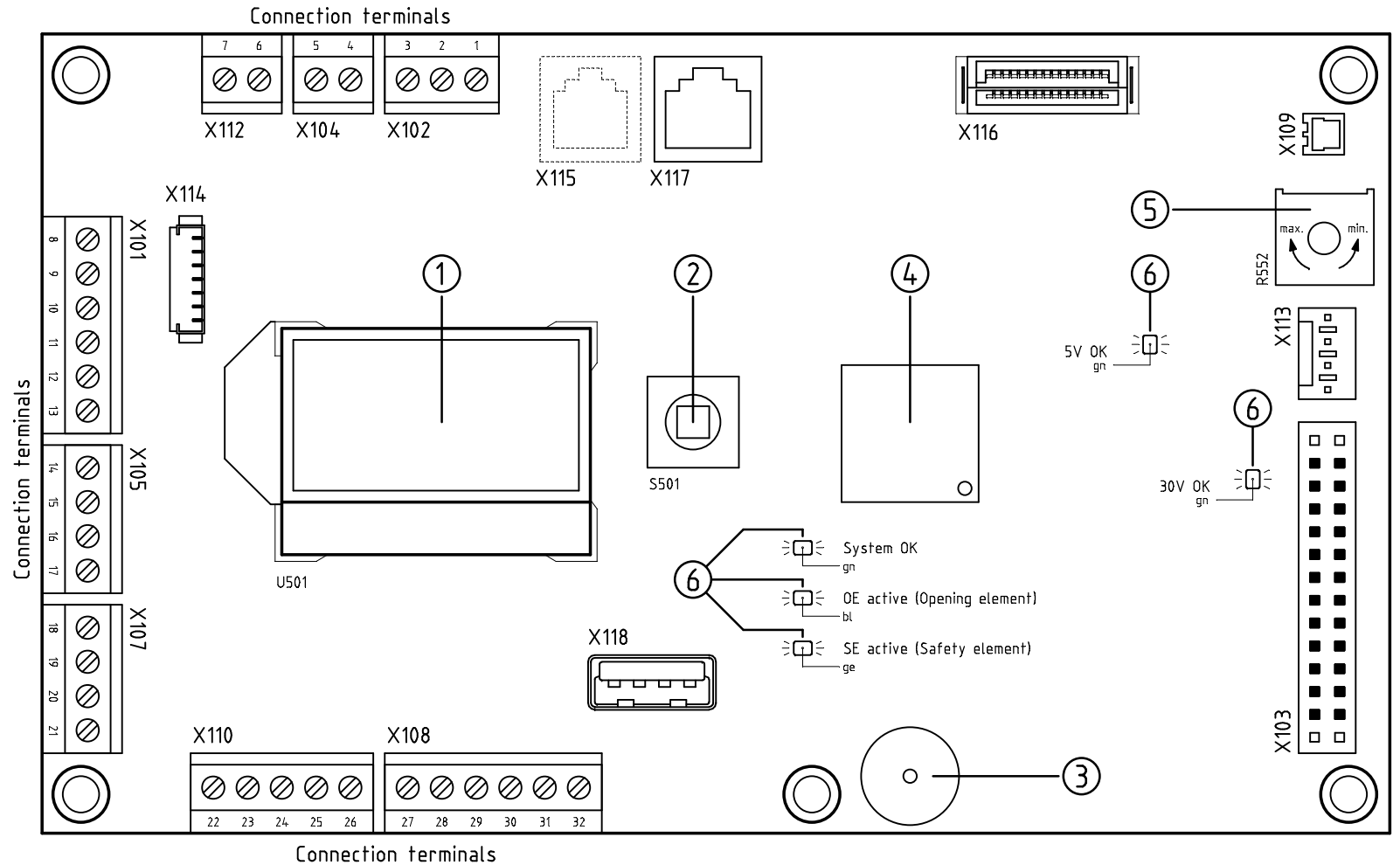

Color LED:

gn / grün / vert / verde / green / verde
 bl / blau / bleu / blu / blue / azul
 ge / gelb / jaune / giallo / yellow / amarillo

Stückliste		a	12/5.16/13.11.13	at	e		Gezeichnet	07.03.12	at	Ursprung:	
Ohne sep.	X	b	13*029/05.06.15	at	f		Geprüft			Ersatz für:	
Sep. gl. Nr.		c	13*154/09.10.15	at	g		Freigegeben				
Sep. and. Nr.		d			h						

WIRING DIAGRAM
 ETS 73 and ETS 64-R
 Control PCB

Anlage:

Blatt-Nr. 1
 Anz. Blatt 7

E4-0141-713c_ECO

ETS 73, ETS 64-R 0548-118

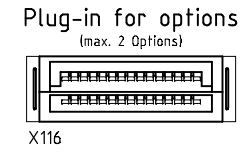
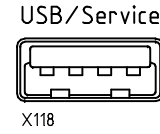
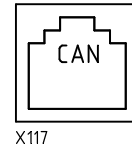
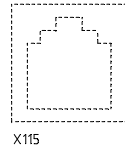

Option:
ETS 64-R inversed "RWA"
(RWA = Smoke and heat extraction system)

Total load +24V: max. 2A
⊕ If element is missing, put a jumper.

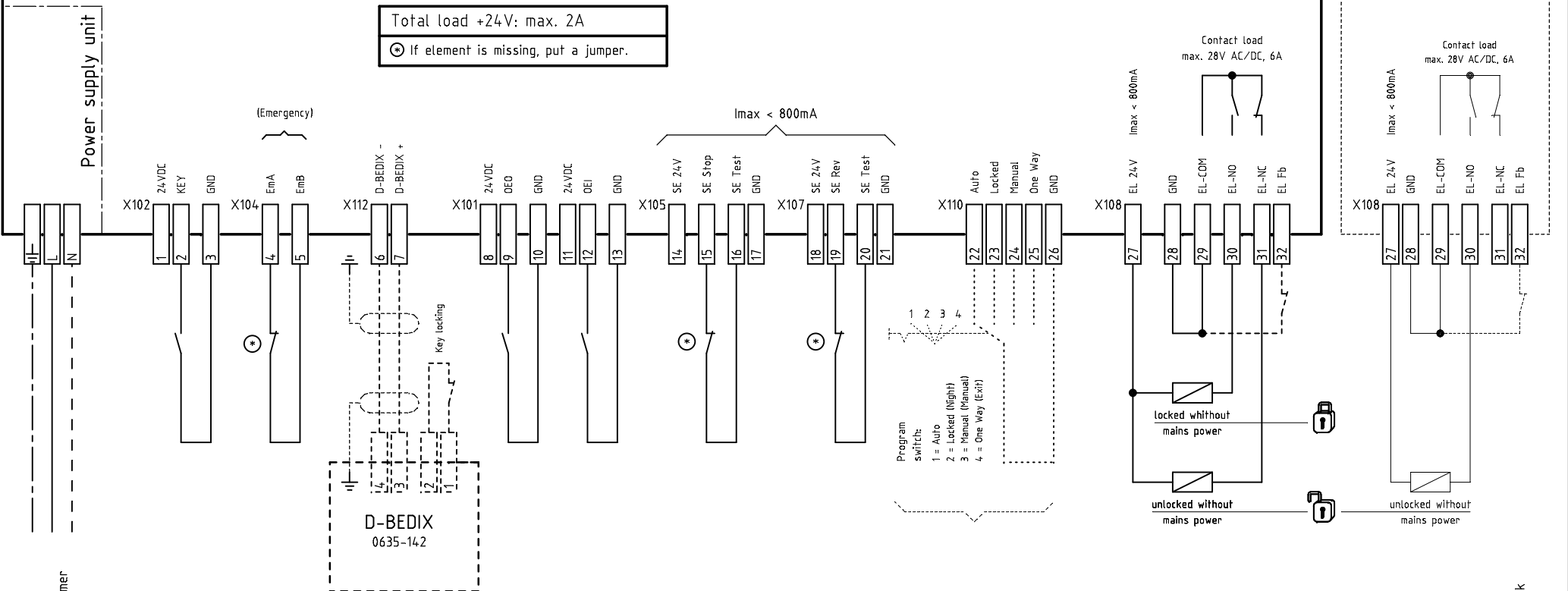

Power supply 230V, 50Hz
fuse 13A supplied by customer

Key-operated switch
Emerg.-closing/-opening
Emergency Stop

Option D-BEDIX
0635-142

Opening comand outside
Opening comand inside

Safety element
Stop
Safety element
Reversing

Program switches:
1 = Auto
2 = Locked (Night)
3 = Manual (Manual)
4 = One Way (Exit)

External program selector:

Motor lock
or electric lock
Optionally:
Feedback signal motor lock
or electric lock
Softswitch El Fb NO/NC

Electric lock
Optionally:
Feedback signal electric lock
Softswitch El Fb NO/NC

Stückliste	a	12.5.16/13.11.13	at	e	Gezeichnet	07.03.12	at	Ursprung:	WIRING DIAGRAM ETS 73 and ETS 64-R Occupation of terminals	Anlage: 1-winged	Blatt-Nr. 2 Anz.Blatt 7	E4-0141-713c_ECO
Ohne sep.	b	13*029/05.06.15	at	f	Geprüft							
Sep. gl. Nr.	c	13*154/09.10.15	at	g	Freigegeben							
Sep. and. Nr.	d			h								

Position of motor plug in function of the assembly version:

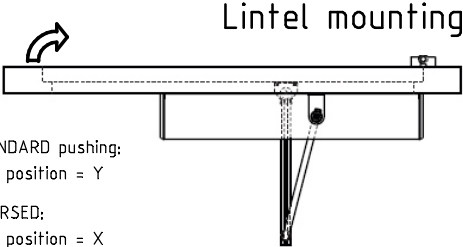
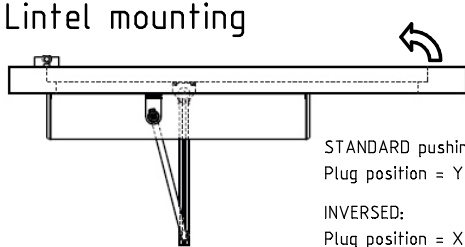
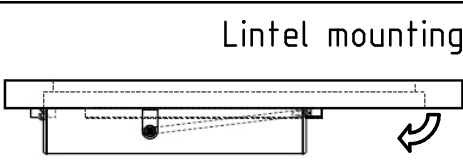
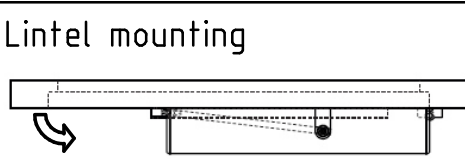
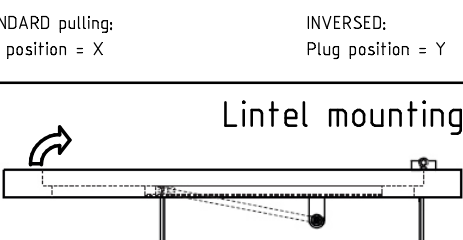
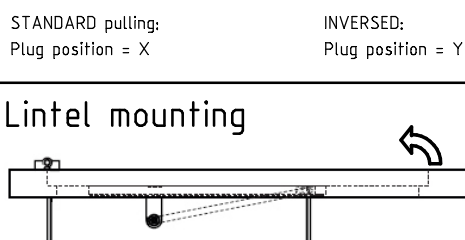
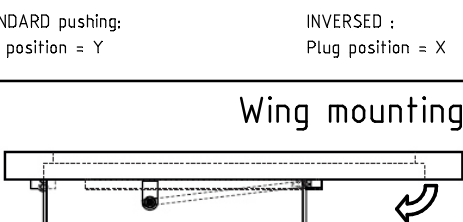
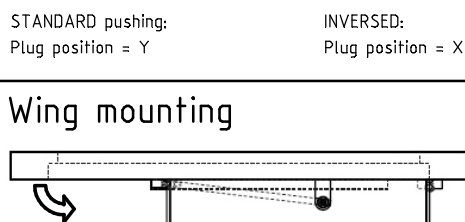
DIN left		DIN right	
<p>Lintel mounting</p>  <p>STANDARD pushing: Plug position = Y</p> <p>INVERSED: Plug position = X</p>		<p>Lintel mounting</p>  <p>STANDARD pushing: Plug position = Y</p> <p>INVERSED: Plug position = X</p>	
<p>Lintel mounting</p>  <p>STANDARD pulling: Plug position = X</p> <p>INVERSED: Plug position = Y</p>		<p>Lintel mounting</p>  <p>STANDARD pulling: Plug position = X</p> <p>INVERSED: Plug position = Y</p>	
<p>Lintel mounting</p>  <p>STANDARD pushing: Plug position = Y</p> <p>INVERSED : Plug position = X</p>		<p>Lintel mounting</p>  <p>STANDARD pushing: Plug position = Y</p> <p>INVERSED: Plug position = X</p>	
<p>Wing mounting</p>  <p>STANDARD pushing: Plug position = Y</p> <p>INVERSED: Plug position = X</p>		<p>Wing mounting</p>  <p>STANDARD pushing: Plug position = Y</p> <p>INVERSED: Plug position = X</p>	

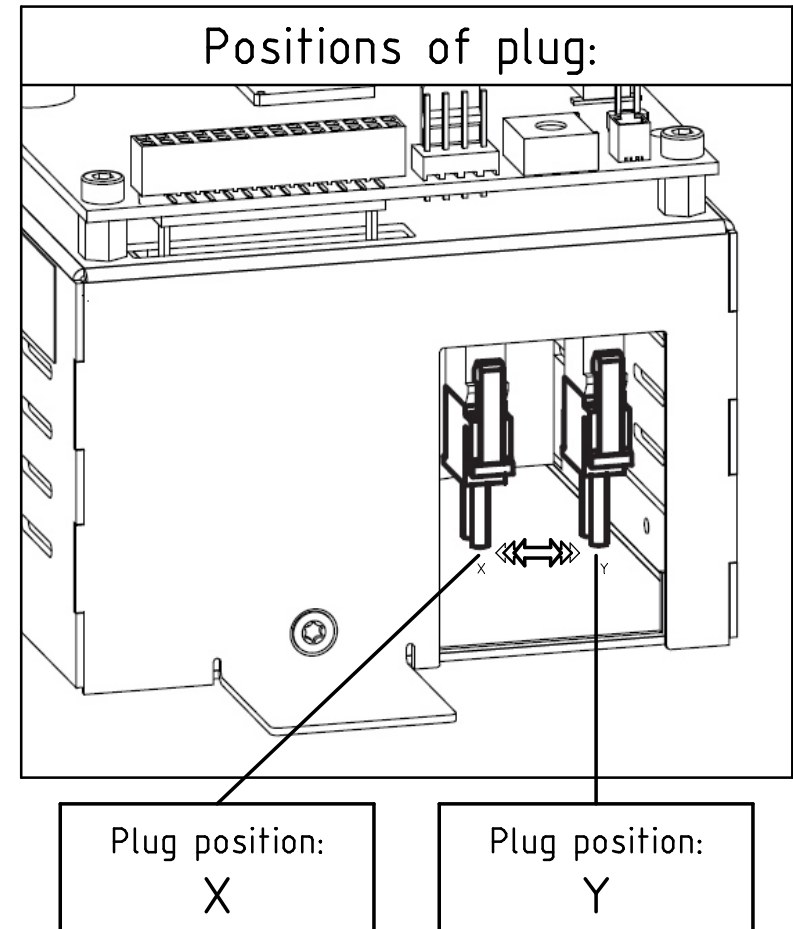

Stückliste		a	12.5.16/13.11.13 at	e		Gezeichnet	26.11.13 at	Ursprung:
Ohne sep.	<input checked="" type="checkbox"/>	b	13.029/05.06.15 at	f		Geprüft		
Sep. gl. Nr.	<input type="checkbox"/>	c	13.154/09.10.15 at	g		Freigegeben		Ersatz für:
Sep. and. Nr.	<input type="checkbox"/>	d		h				

WIRING DIAGRAM
ETS 73 and ETS 64-R
Setting of motor damping

Anlage:
Mounting variants

Blatt-Nr. 3
Anz.Blatt 7

E4-0141-713c_ECO

ETS 73, ETS 64-R 0548-118

Total load +24V; max. 2A
 Ⓢ If element is missing, put a jumper.

Master

M A S T E R		
Parameter:	Setting range:	Default:
DubleD	MastrA (B)	OFF
AcSeq	0..110°	20°

- Opening period for 1-wing operation
 - Starting retard (T-Delay) for Master

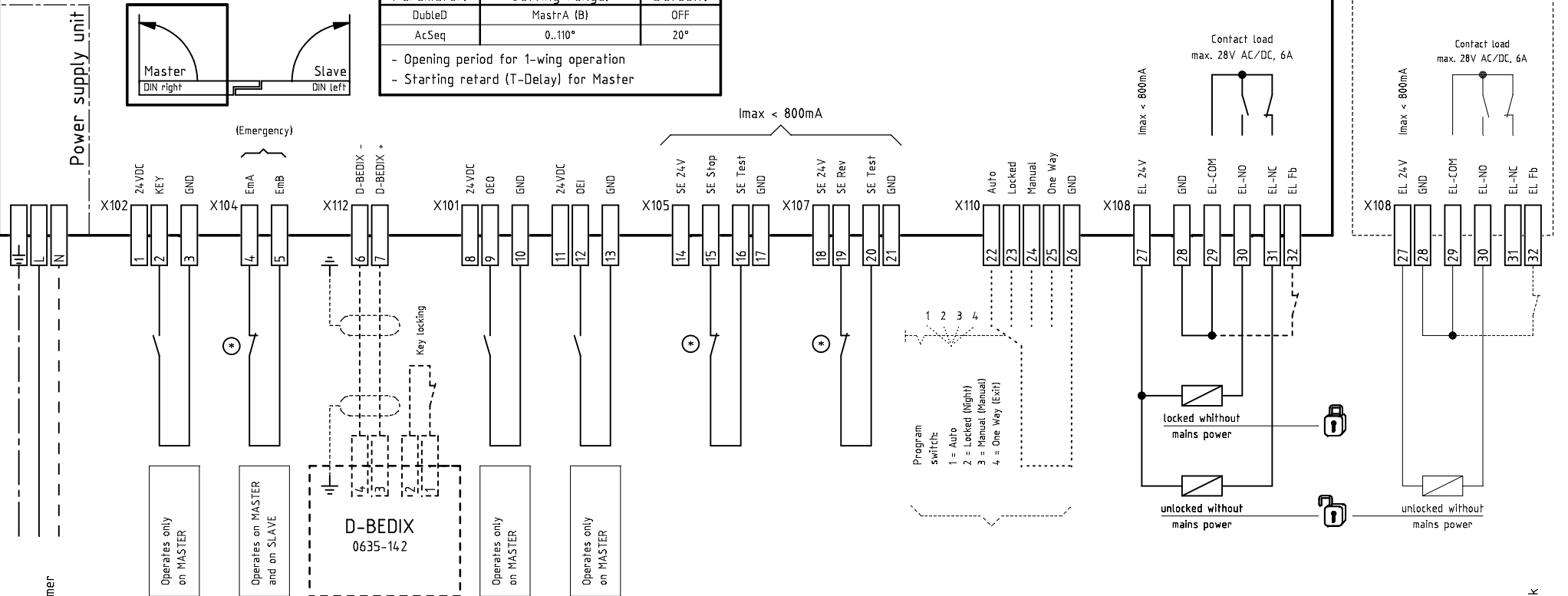

Option:
 ETS 64-R inversed "RWA"
 (RWA = Smoke and heat extraction system)

Power supply 230V, 50Hz fuse 13A supplied by customer

Key-operated switch

Emerg.-closing/-opening Emergency Stop

Option D-BEDIX

Opening command outside

Opening command inside

Safety element Stop

Safety element Reversing

External program selector:

Motor lock or electric lock

Optionally: Feedback signal motor lock or electric lock Softswitch El Fb NO/NC

Electric lock

Optionally: Feedback signal electric lock Softswitch El Fb NO/NC

Stückliste	a	12/516/13.11.13 al	e	Gezeichnet	26.11.13 at	Ursprung:
Ohne sep.	b	13/029/05.06.15 al	f	Geprüft		
Sep. gl. Nr.	c	13/154/09.10.15 al	g	Freigegeben		Ersatz für:
Sep. and. Nr.	d		h			

WIRING DIAGRAM
 ETS 73 and ETS 64-R
 Master

Anlage:
 Double door, Closing sequence

Blatt-Nr. 4
 Anz.Blatt 7
E4-0141-713c_ECO

ETS 73, ETS 64-R 0548-118

Slave

Total load +24V: max. 2A
 * If element is missing, put a jumper.

S L A V E		
Parameter:	Setting range:	Default:
DubleD	SlaveA (B)	OFF
AoSeq	0..110°	20°

- Opening period for 1-wing operation
 - Starting retard (T-Delay) for Slave

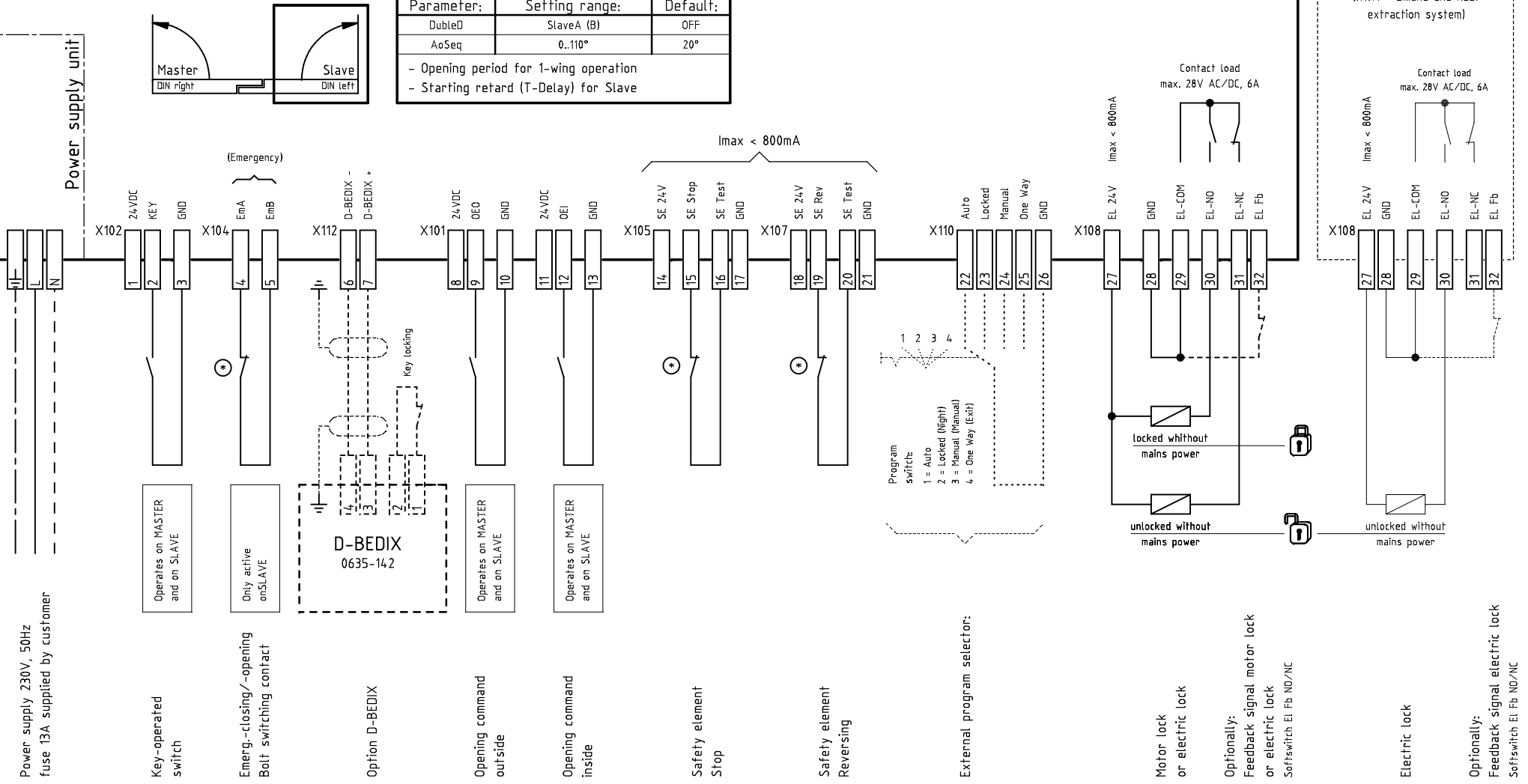

Option:
 ETS 64-R inversed "RWA"
 (RWA = Smoke and heat extraction system)

Stückliste	a	12/5/16/13.11.13 al	e	Gezeichnet	26.11.13 at	Ursprung:	WIRING DIAGRAM ETS 73 and ETS 64-R Slave	Anlage: Double door, Closing sequence	Blatt-Nr. 5 Anz.Blatt 7	E4-0141-713c_ECO
Ohne sep.	b	13/029/05.06.15 al	f	Geprüft		Ersatz für:				
Sep. gl. Nr.	c	13/154/09.10.15 al	g							
Sep. and. Nr.	d		h	Freigegeben						

ETS 73, ETS 64-R 0548-118

Side A

Total load +24V: max. 2A
 Ⓢ If element is missing, put a jumper.

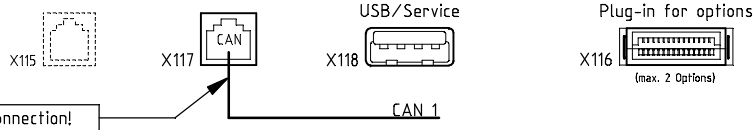

Setting of parameters						S I D E A		
Parameter:	Setting range:	Default:	Parameter:	Setting range:	Default:			
DubleD	MastrA	OFF	ILAuto	Inacti	Active	Active		
InterL	SideA	OFF	ILExit	Inacti	Active	Active		
			ILNigh	Inacti	Active	Active		

Option:
 ETS 64-R inversed "RWA"
 (RWA = Smoke and heat extraction system)

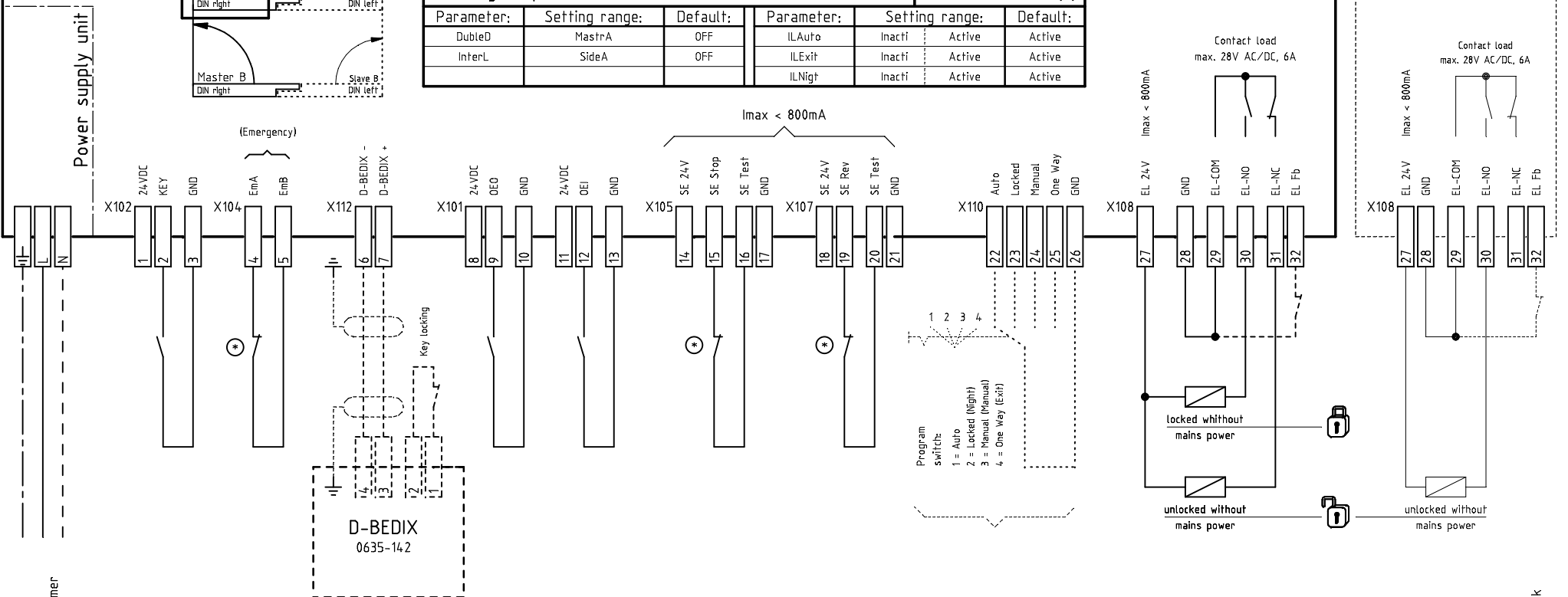

- Power supply 230V, 50Hz fuse 13A supplied by customer
- Key-operated switch
- Emerg.-closing/-opening Emergency Stop
- Option D-BEDIX
- Opening comand outside
- Opening comand inside
- Safety element Stop
- Safety element Reversing
- External program selector:
- Motor lock or electric lock
- Optionally: Feedback signal motor lock or electric lock Softswitch EL Fb NO/NC
- Electric lock
- Optionally: Feedback signal electric lock Softswitch EL Fb NO/NC

ETS 73, ETS 64-R 0548-118

Side B

Total load +24V: max. 2A
 * If element is missing, put a jumper.

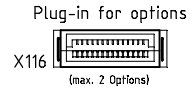
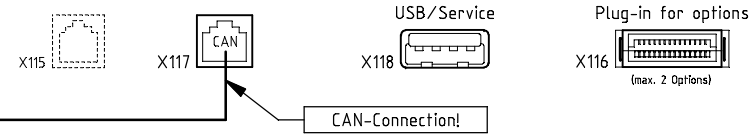

Option:
 ETS 64-R inversed "RWA"
 (RWA = Smoke and heat extraction system)

Setting of parameters						S I D E B		
Parameter:	Setting range:	Default:	Parameter:	Setting range:	Default:			
DubleD	MastrB	OFF	ILAuto	Inacti	Active	Active		
InterL	SideB	OFF	ILExit	Inacti	Active	Active		
			ILNigt	Inacti	Active	Active		

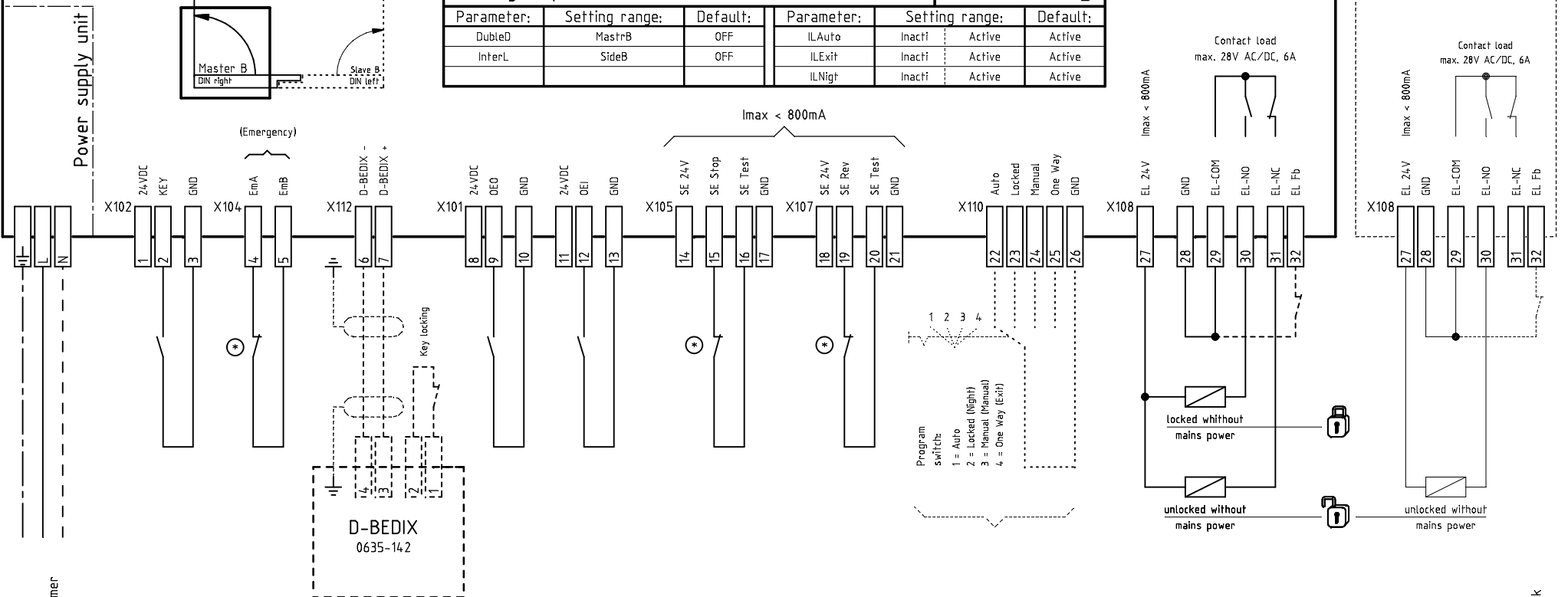

Power supply 230V, 50Hz
 fuse 13A supplied by customer

Key-operated switch

Emerg.-closing/-opening
 Emergency Stop

Option D-BEDIX

Opening comand outside

Opening comand inside

Safety element
 Stop

Safety element
 Reversing

External program selector:

Motor lock
 or electric lock

Optionally:
 Feedback signal motor lock
 or electric lock
 Softswitch El Fb ND/NC

Electric lock

Optionally:
 Feedback signal electric lock
 Softswitch El Fb ND/NC

Stückliste	a	12/516/13.11.13 at	e	Gezeichnet	26.11.13 at	Ursprung:
Ohne sep.	b	13/029/05.06.15 al	f	Geprüft		
Sep. gl. Nr.	c	13/154/09.10.15 al	g	Freigegeben		Ersatz für:
Sep. and. Nr.	d		h			

WIRING DIAGRAM
 ETS 73 and ETS 64-R
 Side B

Anlage:
 Interlock-system

Blatt-Nr. 7
 Anz.Blatt 7

E4-0141-713c_ECO



ECO

ECO Schulte GmbH & Co. KG
 Iserlohner Landstrasse 89
 D-58706 Menden

SWISSDOOR
 DØRTEKNIK FOR PROFESSIONELLE

Danish Seller:

Swissdoor ApS
 Stenhuggervej 2
 DK-5471 Soendersoe
 Tlf.: +45 86 28 00 00
 mail@swissdoor.dk
 www.swissdoor.dk

Optional relay PCB for
 drive mechanism of swing door ETS 73

Notes description

- | |
|--|
| Diagram drawn: door is closed; mains off |
| ⊛ If element is missing, put a jumper. |
| ⌚ Total load +24V: Max. 2A |

Optional relay PCB for ETS 73

0548-215

⚠ Contact load in case of 30VDC; 5A ohmic

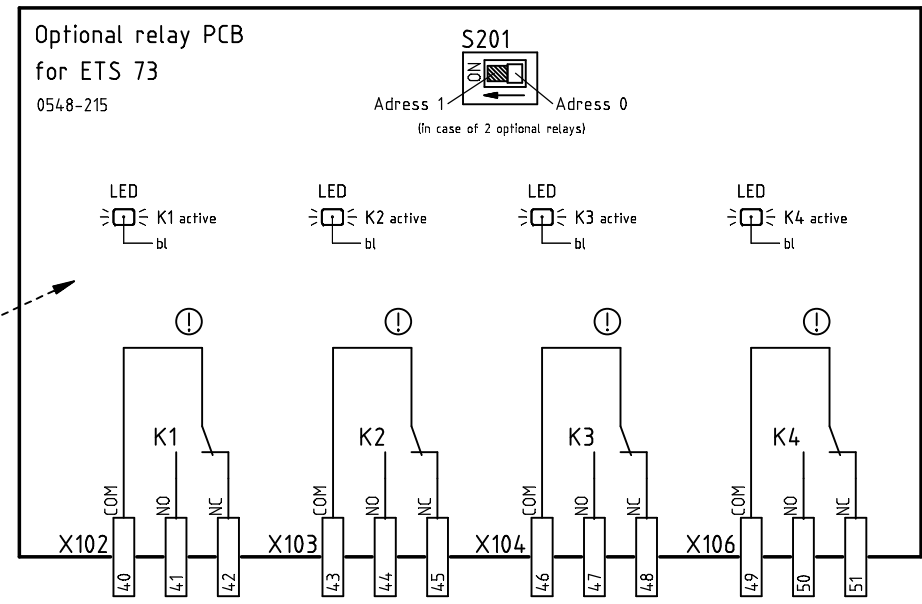
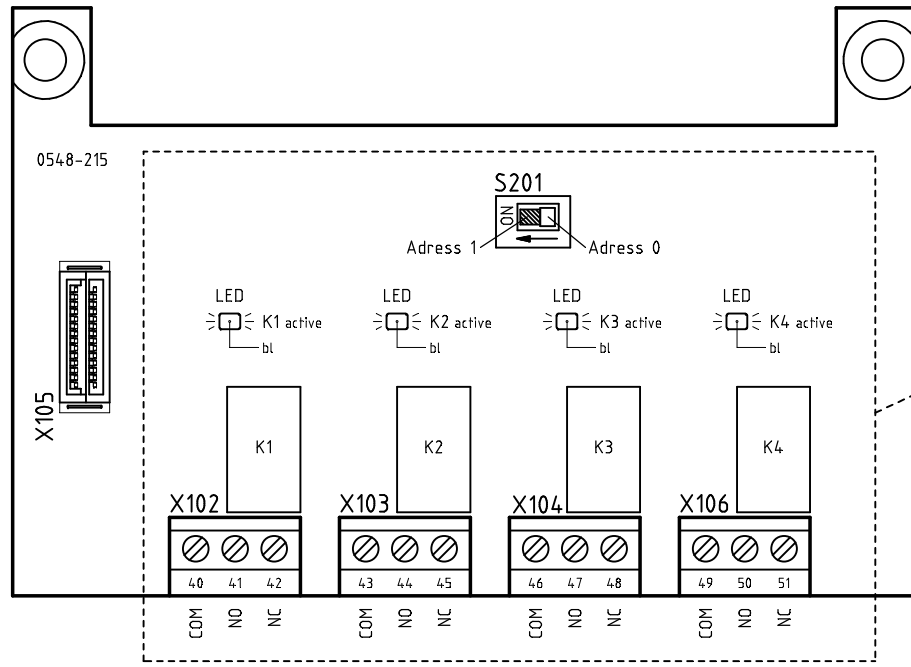

X105
Plug-in for options
(one further option)

S201
Address
(in case of 2 optional relays)

Color LED:
bl / blau / bleu / blu / blue / azul

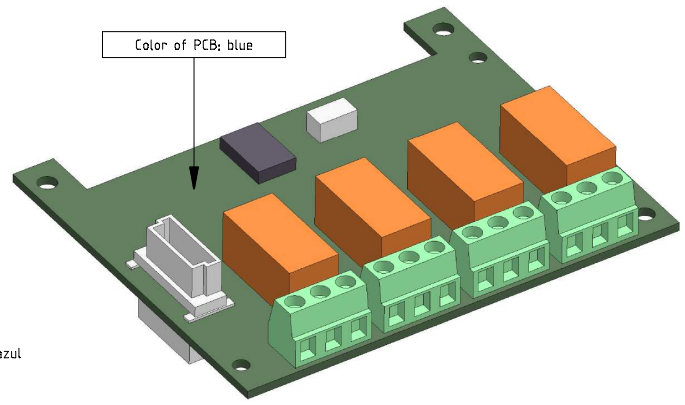

Stückliste	a	E4-0141-715a_	e	Gezeichnet	25.09.13 at	Ursprung:	WIRING DIAGRAM Optional relay PCB for drive mechanism of swing door ETS 73	Anlage:	Blatt-Nr. 1 Anz.Blatt 1	E4-0141-715a_ECO
Ohne sep.	b		f	Geprüft		Ersatz für:				
Änd.	c		g							
Sep. gl. Nr.	d		h	Freigegeben						

Motorised locks with direct connection of coil

Control unit ETS 73 / ETS 64-R

Attention!

It's important to K E E P
the jumper between
terminals 28+29
on ETS 73 / ETS 64-R !

Contact load
max. 28V AC/DC, 6A

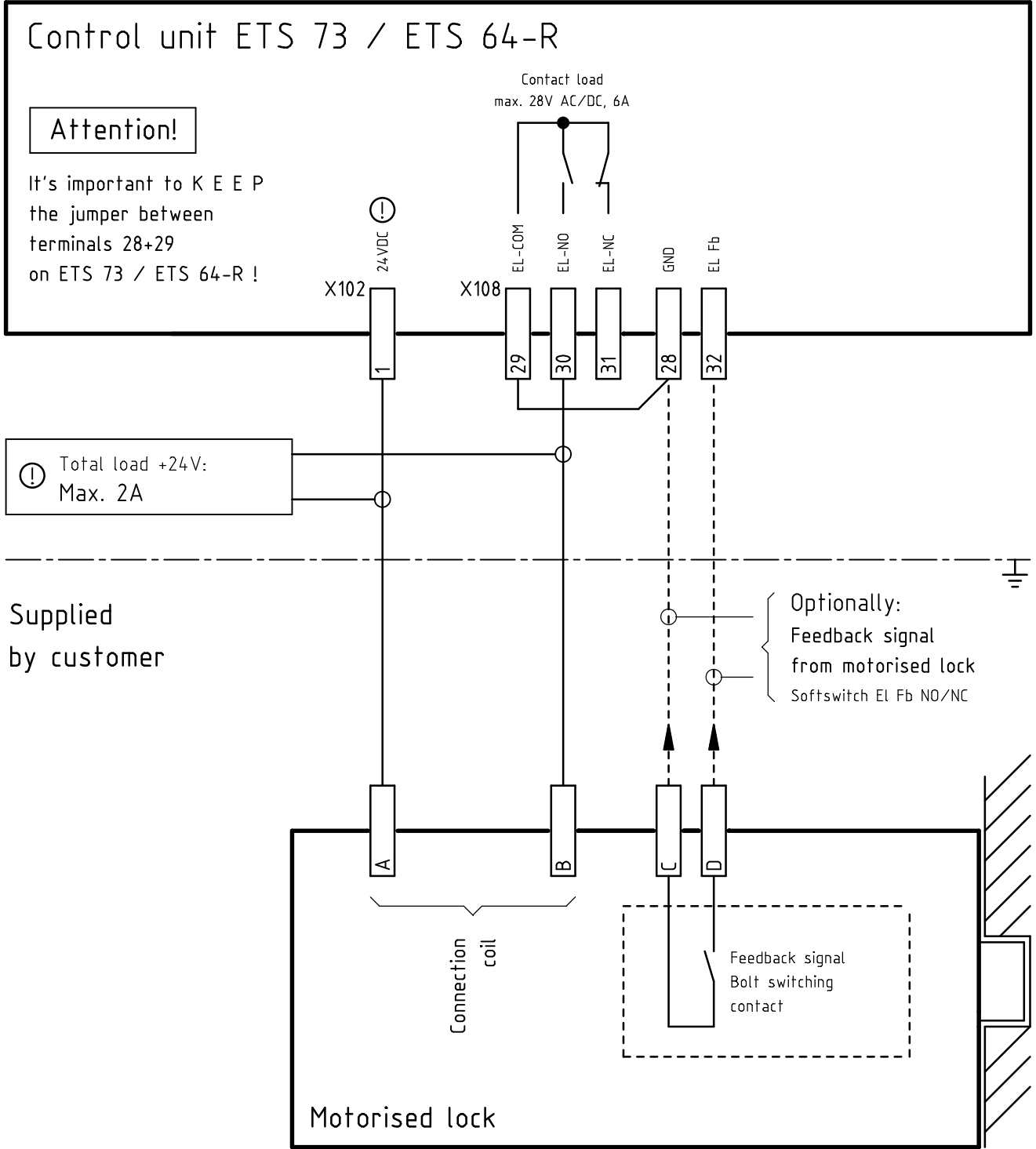

⚠ Total load +24V:
Max. 2A

Supplied
by customer

Optionally:
Feedback signal
from motorised lock
Softswitch EL Fb NO/NC

Ohne sep. Stückliste	<input checked="" type="checkbox"/>	a	13'491/31.08.16 al	e		Gezeichnet	30.08.16 al	Ursprung:	Masstab:
Sep. Stückliste gleicher Nr.	<input type="checkbox"/>	b		f		Geprüft		E4-0142-180a	
Sep. Stückliste anderer Nr.	<input type="checkbox"/>	c		g		Normgeprüft	-----	Ersatz für:	
		d		h		Freigegeben			

Anlage:	Auftrags-Nr. 0142	Blatt-Nr. 1 Anz.Blatt 3
---------	----------------------	----------------------------

 Swissdoor ApS Tlf.: +45 86 28 00 00 mail@swissdoor.dk www.swissdoor.dk	Supplementary page Motorised locks with direct connection of coil	E4-0142-180a_EC0
---	---	------------------

Motorised locks with its own evaluation control

Control unit ETS 73 / ETS 64-R

Attention!

It's important to
R E M O V E jumper
between terminals
28+29 on ETS 73 / ETS 64-R !

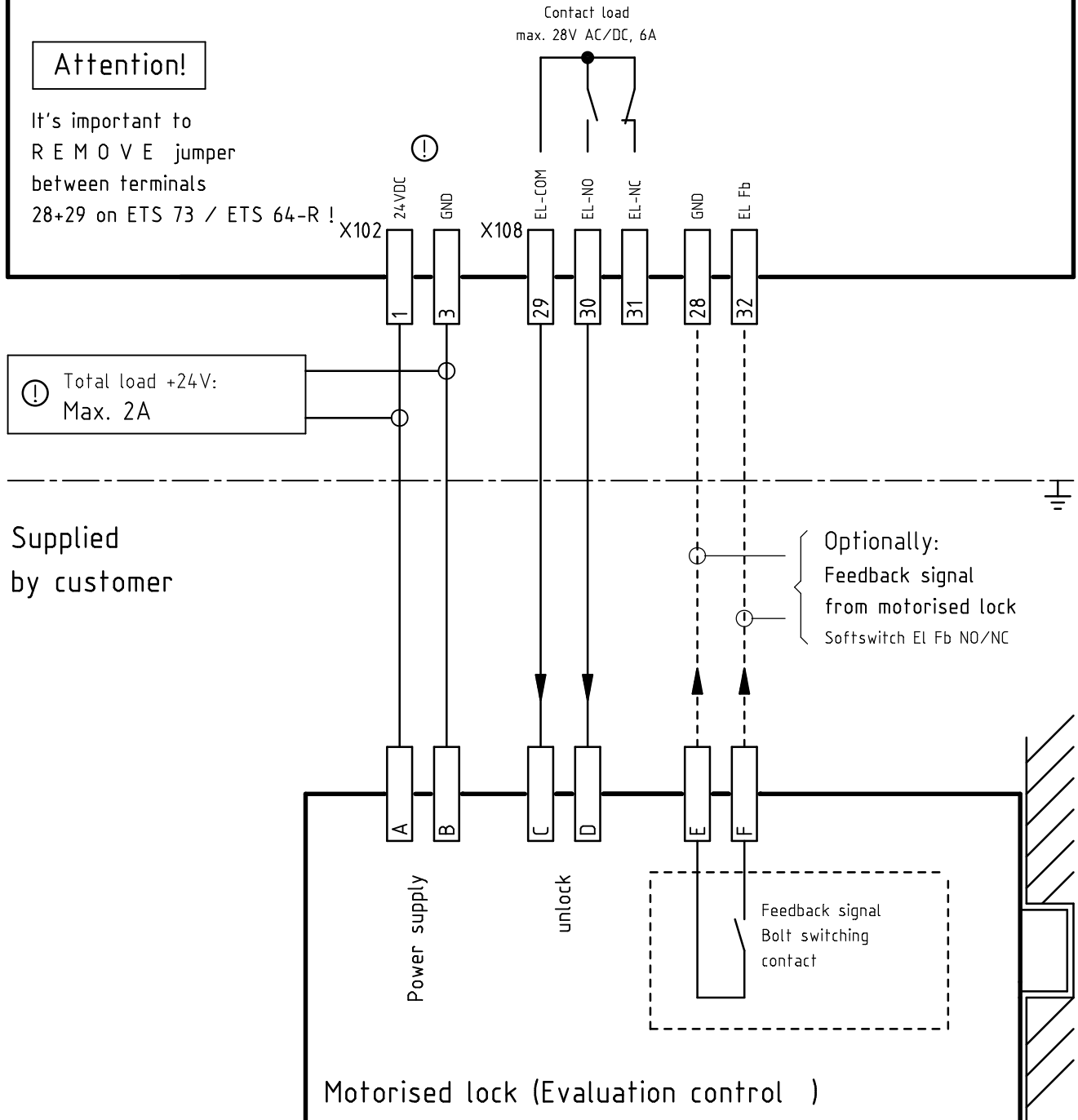

Ohne sep. Stückliste	<input checked="" type="checkbox"/>	a	13'491/31.08.16 al	e		Gezeichnet	30.08.16 al	Ursprung:	Masstab:
Sep. Stückliste gleicher Nr.	<input type="checkbox"/>	b		f		Geprüft		E4-0142-180a	
Sep. Stückliste anderer Nr.	<input type="checkbox"/>	c		g		Normgeprüft	-----	Ersatz für:	
		d		h		Freigegeben			

Anlage:

Auftrags-Nr.
0142Blatt-Nr. 2
Anz.Blatt 3

SWISSDOOR
DÖRTEKNIK FOR PROFESSIONELLE

Swissdoor ApS
Tlf.: +45 86 28 00 00
mail@swissdoor.dk
www.swissdoor.dk

Supplementary page
Motorised locks
with its own evaluation control

E4-0142-180a_EC0

Motorised locks with apart evaluation control and separate power supply

Control unit ETS 73 / ETS 64-R

Attention!

It's important to
R E M O V E jumper
between terminals
28+29 on ETS 73 / ETS 64-R !

Contact load
max. 28V AC/DC, 6A

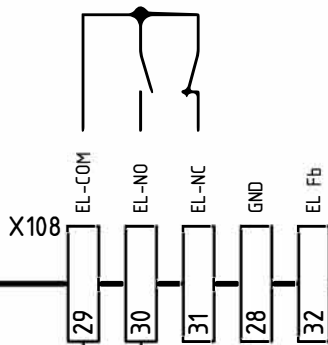

Supplied
by customer

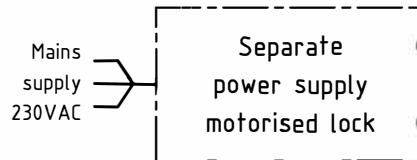

Optionally:
Feedback signal
from motorised lock
Softswitch El Fb NO/NC

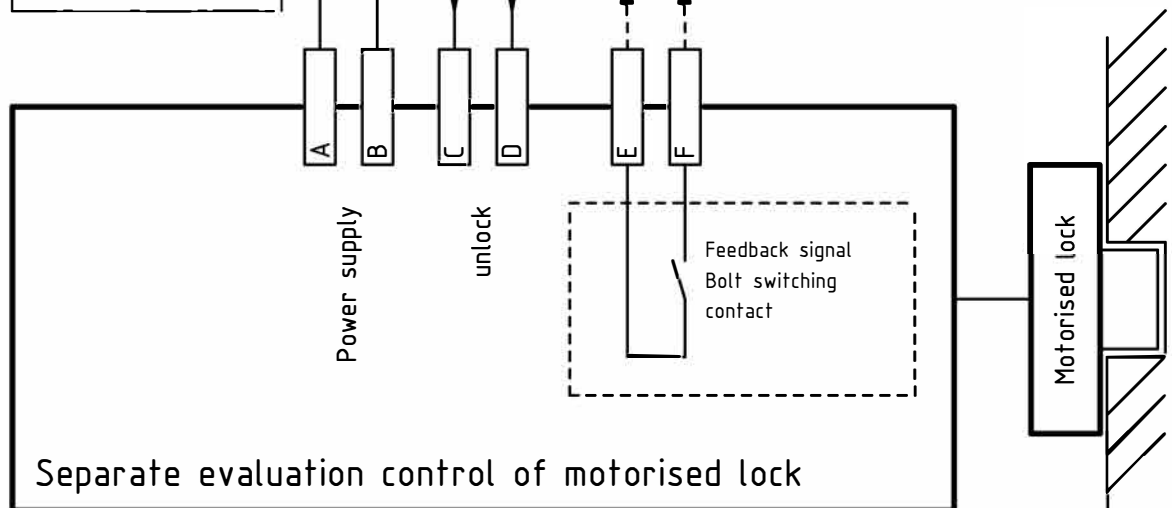

Separate evaluation control of motorised lock

Ohne sep. Stückliste	<input checked="" type="checkbox"/>	a	13'491/31.08.16 al	e		Gezeichnet	30.08.16 al	Ursprung:	Masstab:
Sep. Stückliste gleicher Nr.	<input type="checkbox"/>	b		f		Geprüft		E4-0142-180a	
Sep. Stückliste anderer Nr.	<input type="checkbox"/>	c		g		Normgeprüft	-----	Ersatz für:	
		d		h		Freigegeben			

Anlage:

Auftrags-Nr.
0142

Blatt-Nr. 3
Anz.Blatt 3

SWISSDOOR
DÖRTEKNIK FOR PROFESSIONELLE

Swissdoor ApS
Tlf.: +45 86 28 00 00
mail@swissdoor.dk
www.swissdoor.dk

Supplementary page
Motorised locks with apart evaluation control
and separated power supply

E4-0142-180a_ECC