

# SL60

Linear stem actuator  
Thrust force 600N  
Max. stroke 750mm



## DESCRIPTION FOR TECHNICAL SPECIFICATIONS

Linear electric actuator Topp model SL60 with self-aligning tilting movement, complete with support and fitting accessory for top hung windows. Operation at 230V 50Hz, or, as an alternative, at 24V DC. Max. traction and thrust force 600N. Preset for the parallel connection of two or more actuators, with stroke end microswitches. Available strokes: 180 - 230 - 350 - 550 - 750 mm. CE marked device.

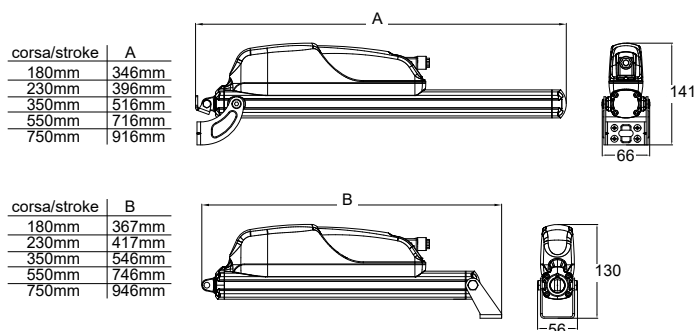

Easy and fast installation due to the coupling railways along the shaft in support of the robust stainless steel mounting bracket

Rapid coupling system between housing and motor-gear unit

High protection IP 55 rated

## TECHNICAL CHARACTERISTICS

	SL60 230V	SL60 24V
Power supply voltage	230V ~ 50Hz	24V DC
Maximum applicable load in thrust		600 N
Maximum applicable load in traction	450 N	500 N
Stroke		180 - 230 - 350 - 550 - 750 mm
Absorbed current	0,33 A	1,35 A
Idle translation speed	12 mm/s	7 mm/s
Duration of the idle stroke		(stroke/idle translation speed)
Double insulated	YES	-
Service Type		S2 of 3 min
Operating temperature		-5°C +50°C
Protection Class		IP 55
Parallel connection option		YES
Stroke end		micro switch
Dimensions		from 337 up to 907x47x104 mm

**CODE                      PRODUCT DESCRIPTION**

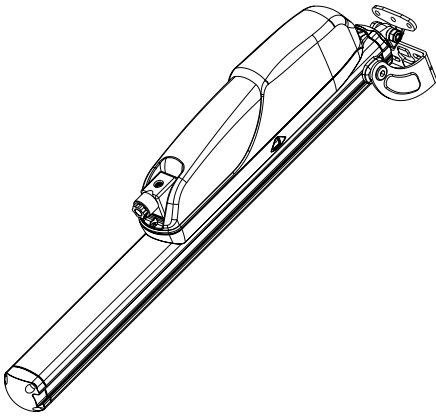

**SL60 standard 1 push point**

3B1#000000294	SL60 linear stem actuator 230V stroke 180 mm
3B1#000000299	SL60 linear stem actuator 230V stroke 180 mm (louvers)
3B1#000000295	SL60 linear stem actuator 230V stroke 230 mm
3B1#000000296	SL60 linear stem actuator 230V stroke 350 mm
3B1#000000297	SL60 linear stem actuator 230V stroke 550 mm
3B1#000000298	SL60 linear stem actuator 230V stroke 750 mm
3B1#000000285	SL60 linear stem actuator 24V stroke 180 mm
3B1#000000290	SL60 linear stem actuator 24V stroke 180 mm (louvers)
3B1#000000286	SL60 linear stem actuator 24V stroke 230 mm
3B1#000000287	SL60 linear stem actuator 24V stroke 350 mm
3B1#000000288	SL60 linear stem actuator 24V stroke 550 mm
3B1#000000289	SL60 linear stem actuator 24V stroke 750 mm

**Description of the standard pattern**

3B1#000000296	SL60 linear stem actuator 230V stroke 350 mm
	Actuator supporting bracket
	Fitting bracket to the frame
	Spare parts

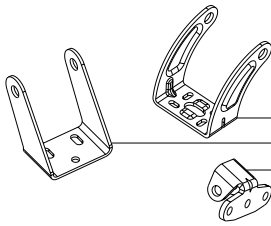

**Accessories and spare parts**

1B1580	Stroke restrictor kit
1B1813	Actuator supporting bracket
1S1603	Actuator supporting bracket for louvers
1S1604	Fitting bracket to the frame
3B1001	Spare parts
3B1002	Spare parts for louvers

Special strokes available.

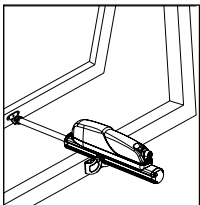

Top-hung windows

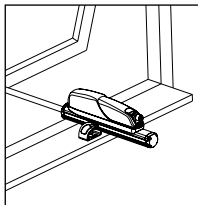

Top-hung windows

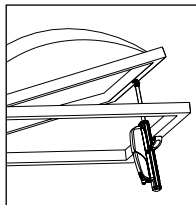

Cupolas

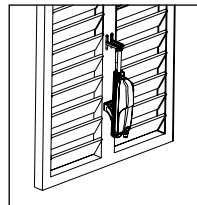

Louvers

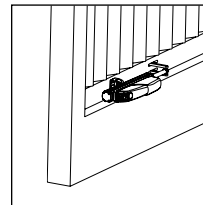

Louvers