

# Safety edges

Safety edges  
ENT-R, ENT-20, ENT-7, ENT-S

## Assembly instructions

### Application

Safety edges (sensors) in combination with a switching unit (signal processing) are components of a safety system (protection system for person detection). The system, or more specifically the safety edges, are used to safeguard shearing and crushing points on power-operated doors, gates and similar automatic fixtures. The safety edges can be installed in any horizontal or vertical position, either single or in combination.

## 1 Types of mounting

### Standard

#### End caps on both ends

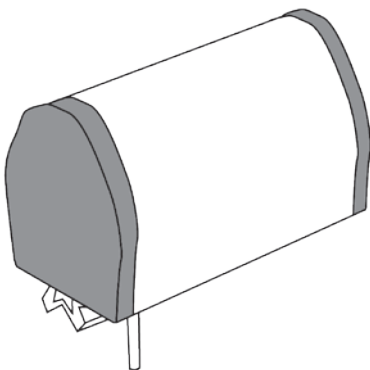

#### Top, rubber profile closed:

- 1 end cap
- Profile chamber sealed

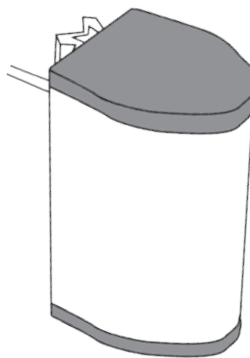

#### Bottom, rubber profile closed:

- 1 end cap
- Profile chamber sealed

### As an option for vertical applications

#### Top, rubber profile closed:

- 1 end cap
- Profile chamber sealed

#### Bottom, rubber profile open:

- no end cap
- switching chamber not sealed

## 2 Preparing the safety edge and assembling the contact strip

### 2.1 Measuring the safety edge

Trim aluminium profile to the correct length and plan type of cable entry/exit, drill holes (countersunk).

Aluminium profile length = Rubber profile length (L)

### 2.2 Trimming the rubber profile

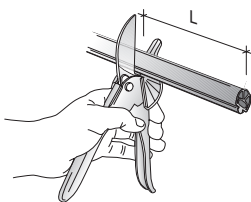

Using the rubber shears, trim the rubber profile to the desired length L.

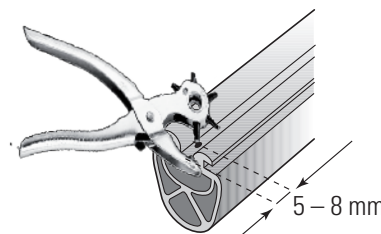

For the cable feed-through, make a small hole (3,5 mm) with hole punch pliers about 5 – 8 mm from the edge.



The switching chamber for the contact strip must not be damaged unnecessarily as incoming water may impair the safety function of the strip.

### 2.3 Trimming the contact strip

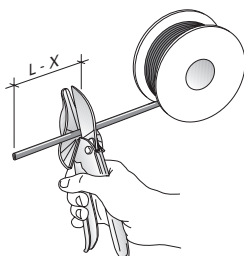

Trim the contact strip to length (L – X). Be sure to cut at 90° angles!

The contact strip is shorter than the rubber profile by the length of the end pieces used:

	Cable and end piece	Cable (both ends)	Types
X =	55 mm	60 mm	standard
X =	50 mm	55 mm	vertical

## 2.4 Fitting the end pieces

### 2.4.1 Heat end pieces to 45 °C (if possible)

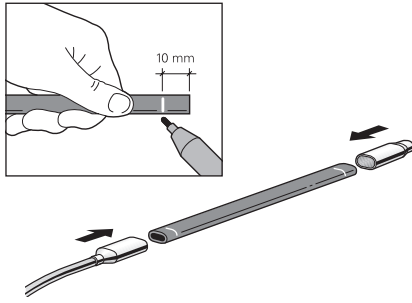

Measure off and mark a point exactly 10 mm from each end of the contact strip. Then slide on the end pieces up to the marks (tolerance  $\pm 1$  mm).

## 2.5 Crimping the end pieces

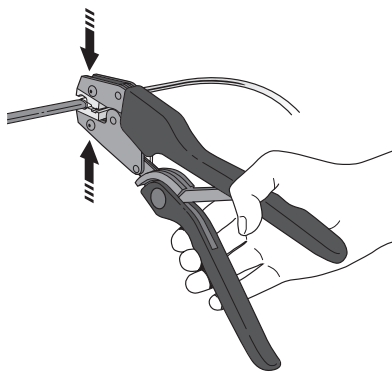

Using the crimping tool, crimp the end pieces at both ends and check they are secure. Squeeze pliers firmly together.

#### Notice:

For contact strips ENT-R and ENT-20, end pieces ENEH-... must be crimped on with ES-PRESS pliers (ClickLine, CoverLine and StandardLine).

For contact strips ENT-7 and ENT-S, use ENES-... end pieces and ESS-PRESS (S-Line) pliers.

#### ES-PRESS

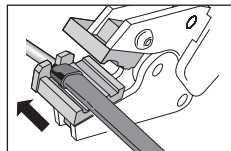

ENT-R  
ENT-20

#### ESS-PRESS

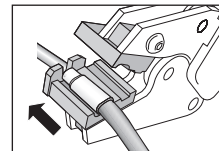

ENT-7  
ENT-S

## 2.6 Testing the contact strip

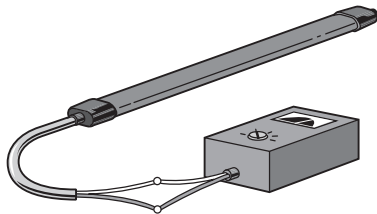

	End pieces		
	ENEH-8 ENES-8	ENEH-0 ENES-0	ENEH-K... ENES-K...
	8.1 - 8.5 k $\Omega$	$\infty$	$\infty$
	< 500 $\Omega$	< 500 $\Omega$	< 500 $\Omega$



**Warning: The contact strip must be tested with an ohmmeter to ensure correct functioning BEFORE it is fitted in the rubber profile! In the case of two-ended cables, test both ends!**

## 2.7 Feeding in the contact strip

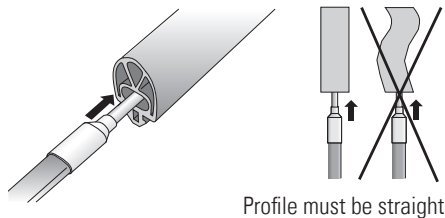

When feeding the contact strip into the rubber profile, no lubricants such as water, talc, oils, greases or silicone spray, should be used. Otherwise, the sealing compound applied later on will not bond with the rubber profile and seal the switching chamber.

**Notice:** If the rubber profile is longer than 3 m, it is advisable to pass a length of string through the profile first using compressed air. Tie the string to the cable end of the contact strip and then pull carefully the strip through. A stiff piece of wire is also a suitable aid. Be careful not to damage the switching chamber when feeding the contact strip through!



**Warning: Before sealing, check the functionality (contact-making) of the safety edge again using an ohmmeter! In the case of two-ended cables, test both ends!**

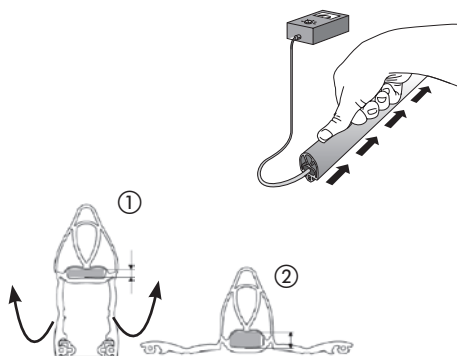

**Notice:** For profiles EPE040/105 and EPE040/081, the arms must be folded up by 90 degrees ① before feeding the contact strip through in order to open up the switching chamber to assist in assembly ②.

### 3 Assembling the safety edge

#### 3.1 Types of mounting for the safety edge

##### Standard

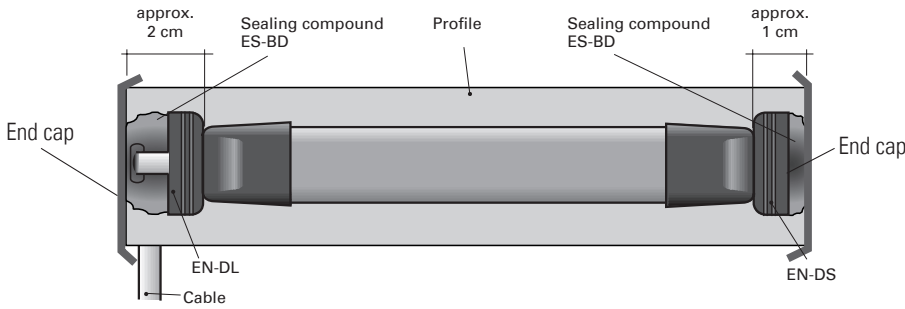

NB: End cap only if rubber profile is sealed

**Note:**

For S-Line use ENS-parts instead of EN-parts

##### Option for vertical applications (sliding gates) only

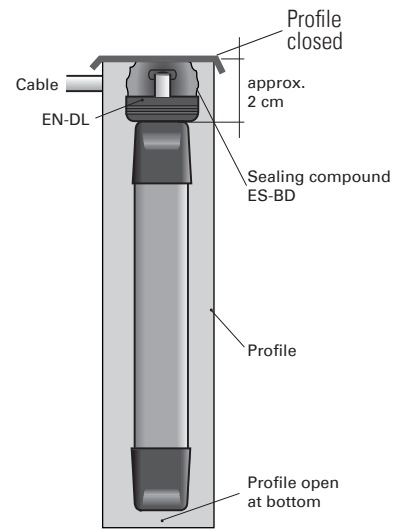

#### 3.2 Sealing the switching chambers in the rubber profile

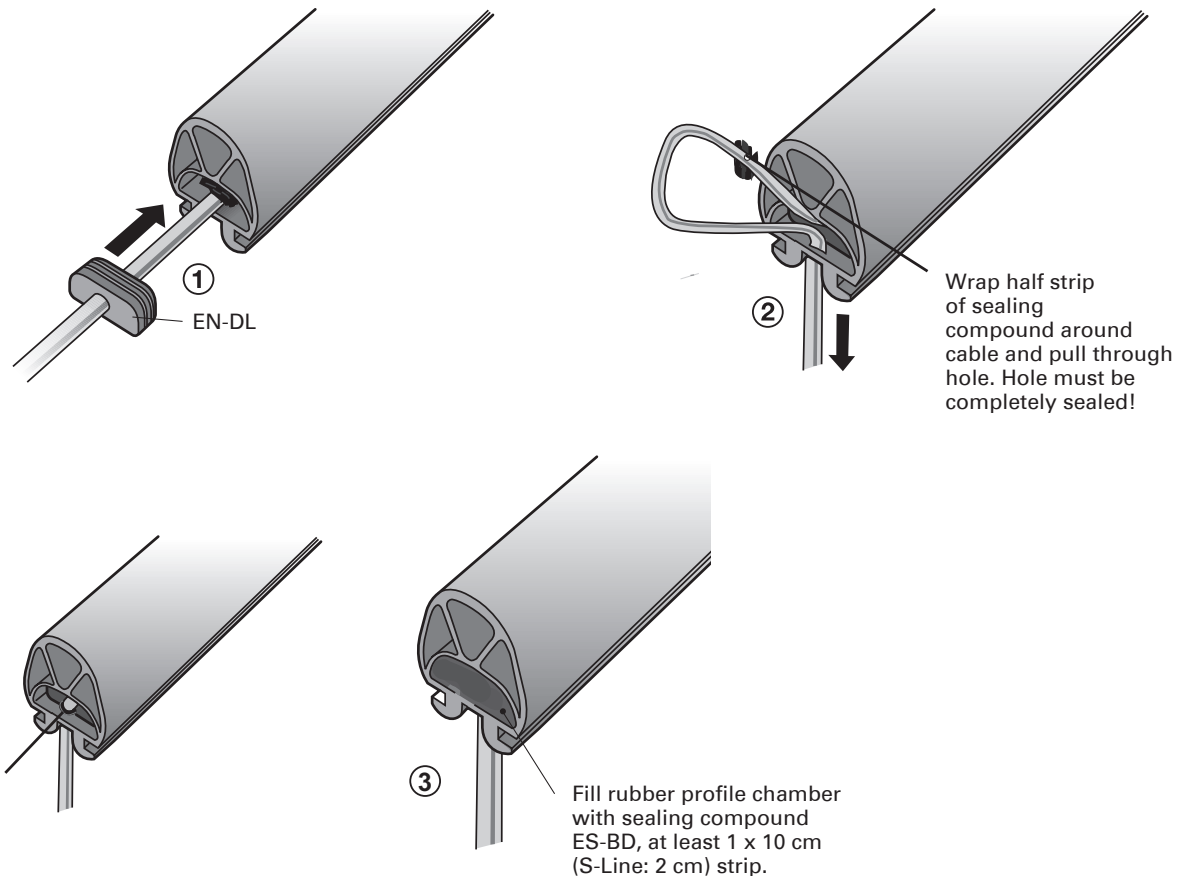

- ① Slide sealing plug EN-DL over cable, inserting at least 4 mm into the profile. Sealing plug EN-DS without hole on the side without a cable.
- ② Wrap ES-BD sealing compound around cable and pull through hole made with punch pliers using long-nosed pliers. The hole must be completely sealed with the compound.
- ③ Then fill the rest of the switching chamber with sealing compound and press down well.

**Note:** For ELE040/081 and ELE040/105: apply EN-KAS

### 3.3 Glueing on the end caps

ES-KLEBER

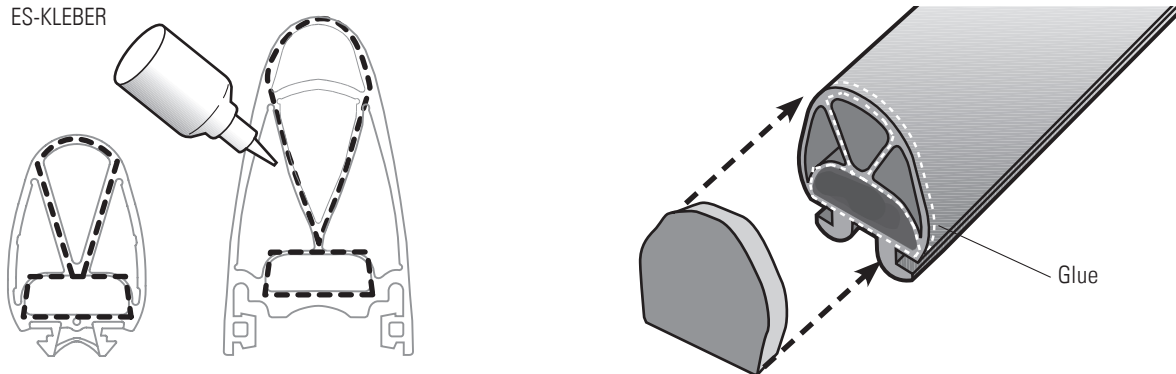

Attach end caps by applying ES-KLEBER to the points shown and hold in place, applying pressure across the whole area, for approx. 10 seconds.

**Note:** No end caps on ELE040/081 and ELE040/105

## 4 Mounting the safety edge

### 4.1 Attaching aluminium strip

Attach aluminium strip to object with **countersunk head screws**. Recommended hole spacing 300 mm. Make sure aluminium strip is securely attached to ends of safety edge. You may have to make holes for the cable to exit.

**NB:** In the case of 2-panel systems, the two profiles should be aligned facing each other. The same applies to any counter sealing profile.

**Notice:** If possible, avoid routing the cable through the aluminium profile as it may press against the switching chamber.

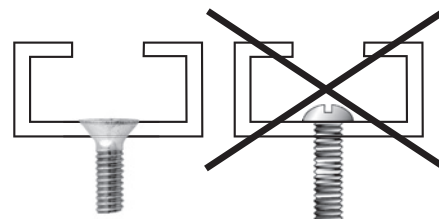

### 4.2 Mounting the rubber profile

- ① Press in profile at both ends
- ② Work from outside inwards

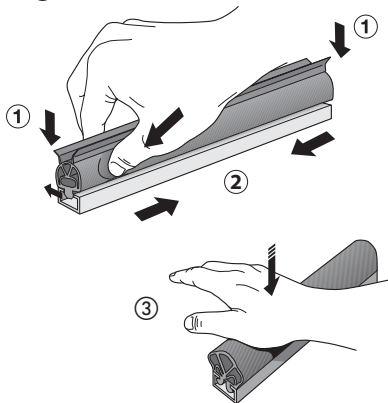

Moisten «click-fit foot» rubber profiles with a solution of soapy water and press into the aluminium profile (do not pull in).

T-foot rubber profiles should be pulled into the aluminium. Any burrs on the aluminium profile must be removed first.

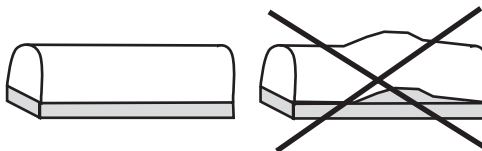

- ③ **To ensure correct functioning of safety edges with a click-fit foot, after mounting, the safety edge must be pressed in along its entire length to make sure the foot engages properly in the aluminium bar. Otherwise, the safety edge will connect through.** Check fit of rubber profile in aluminium strip.

### 4.3 Final checks



**Warning:** Perform a final functional and visual check of the safety edge. Once mounting is complete, test the safety edge on the object to make sure it functions correctly. The protection system must also satisfy the force, overtravel and sensitivity requirements of the standards applicable in the relevant country.

Check the resistance of the safety edge with an ohmmeter.

**Notice:** The overall safety of the machine and its protection systems depends on the quality, reliability and correct connection of the interfaces.

	End pieces		
	ENEH-8 ENES-8	ENEH-0 ENES-0	ENEH-K... ENES-K...
	8.1 - 8.5 kΩ	∞	∞
	< 500 Ω	< 500 Ω	< 500 Ω

## 5 Maintenance

The safety edge is maintenance-free. If damage occurs, such as a brittle or torn rubber profile, non-tight switching chamber, **insufficient contact resistance in the activated state (>500 ohms)** or similar, the safety edge must be replaced immediately. Please request a new one, remembering to state the product designation.

Check the resistance of the safety edge with an ohmmeter, referring to the table above.

## 6 Contact details

### Manufacturer

**Bircher Reglomat AG**  
Wiesengasse 20  
CH-8222 Beringen  
[www.bircher-reglomat.com](http://www.bircher-reglomat.com)

### Danish seller

**Swissdoor ApS**  
Stenhuggervej 2  
DK-5471 Soendersoe  
[mail@swissdoor.dk](mailto:mail@swissdoor.dk)  
[www.swissdoor.dk](http://www.swissdoor.dk)