

# AirMission 1.T

Transmitter to wireless signal transmission system with integrated pressure wave switch

## Short guide

### General

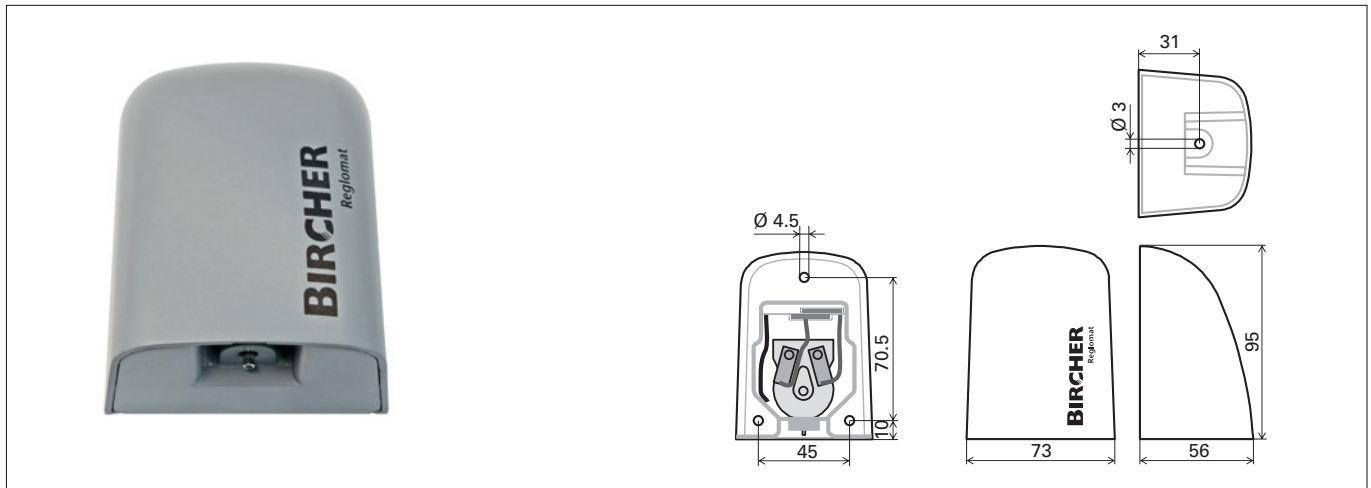

## 1 Safety instructions



**Warning:** Switch off the operating voltage before working on the system. Only trained, qualified personnel may perform installation and startup. The unit may only be opened and repaired by Bircher Reglomat employees. The switching unit may only be used to protect against dangers at crushing and shearing points and at automatic industrial doors (intended use). National and international regulations on industrial door safety must be complied with. Always consider the safety functions of

your application as a whole, never just in relation to one individual section of the system. A risk assessment in advance is mandatory. The installer is responsible for installing the industrial door system correctly.



**It is recommended to change the batteries every year.**

## 2 Common application

### 2.1 Industrial door

Transmitter for monitoring pressure wave system safety edges.

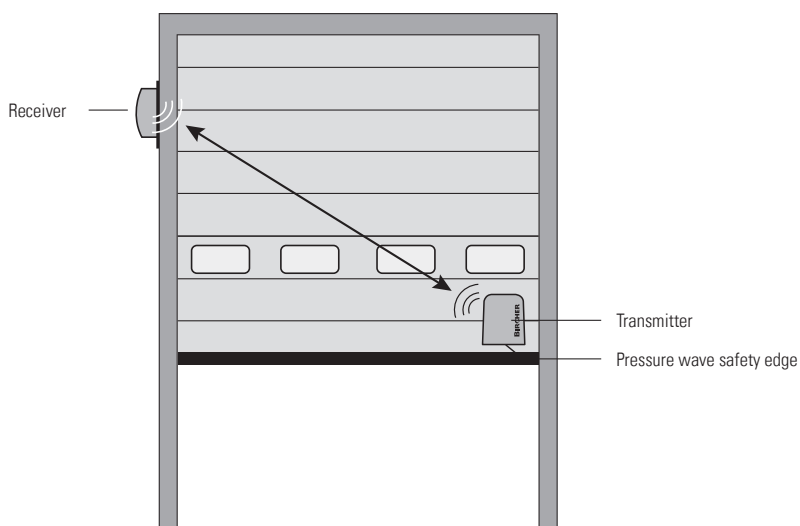

### 3 Start-up

1. Open			2. Carefully pull out PCB		
3. Insert both batteries (front/back)		2x	4. Programming: Pair transmitter with receiver See receiver manual		
5. Slide PCB back into housing		6. Install transmitter		3	
7. Close		8. Connect safety edge with transmitter (rubber hose)		9. System test: Activate the safety edge	

### 4 Battery replacement

1. Open			2. Carefully pull out PCB	
3. Replace both batteries (front / back)		2x	4. Slide PCB back into housing	
5. Close		6. System test: Activate the safety edge		

### 5 Technical data

System	
Frequency bands	868.95 MHz & 869.85 MHz
Range	Under optimum conditions up to 100 m
Response time	25 ms
Pollution degree	2
Working temperature	-20 °C to +55 °C

Transmitter	
Battery power	2 x Lithium 3 V Type CR2032
Power consumption	Transmitting: 17 mA, standby: 16 µA
Protection class IEC 60529	IP54

### 6 Standards EN ISO 13856-2 and EN ISO 13849-1

The AirMission 1.T system itself is not able to check the function of the sensor in response to a pressure pulse. In accordance with D 3.5 of EN ISO 13856-2, a pressure wave system according to category 2 of EN ISO 13849-1 can be designed by checking the pressure wave system

at every machine cycle. On the doors and gates the door/gate control must assure this function in order to satisfy category 2. (→ Figure A.4 of EN ISO 13856-2).

### 7 Contact

#### Danish seller

**Bircher Reglomat AG**  
Wiesengasse 20  
CH-8222 Beringen  
www.bircher-reglomat.com

**Swissdoor ApS**  
Stenhuggervej 2  
DK-5471 Soendersoe  
Denmark  
Tel.: +45 86 28 00 00  
mail@swissdoor.dk  
www.swissdoor.dk

