

## Translation of the original instructions

Switching device with inductive transmission system used in combination with safety edges to avoid dangers at crushing and shearing points in sliding gate systems.

263146F  
08/13

### Safety and warning notices

- The electrical connection may only be set up by an electrician. → The arrangement of the components depends on the structural conditions and the gate design. → Switch off the operating voltage before working on the system. → The switching device monitors pressure-sensitive protective devices from Bircher Reglomat AG (proper use). → Use of components not supplied by Bircher-Reglomat (including safety edges) will render the guarantee and liability null and void. → Connect all operating and switching voltages to the same fuse. → Connect the operating voltage to the same circuit as the industrial door controller. → Disconnect device from mains in the event of a fault. → Protection max. 10 A

### 1 System components

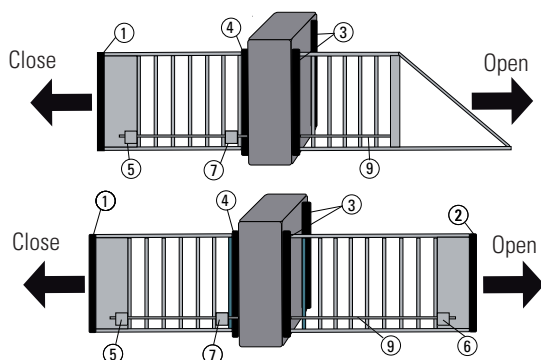

- ① Mobile safety edge CLOSE (primary closing edge)
- ② Mobile safety edge OPEN
- ③ Stationary safety edge CLOSE
- ④ Stationary safety edge OPEN
- ⑤ INTR-MOB61, converter for safety edge ①
- ⑥ INTR-MOB62, converter for mobile safety edge ②
- ⑦ INTR-FIX60, coil
- ⑧ Intra6 2, switching device
- ⑨ Steel cable (see chapter 8.3)

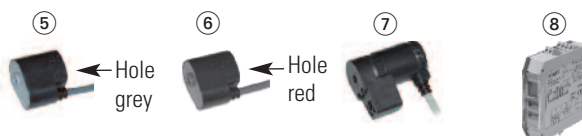

### 2 Electrical connection and terminal diagram

Version	Operating voltage	Stationary safety edge CLOSE ③	Stationary safety edge OPEN ④	Test input	Coil connection ⑦	Output CLOSE	Output OPEN
InTra6 2 InTra6 2.LVAC	+/- A1 -/- A2						

### 3 Operation

Control buttons on device: «Mode» button, «Data» button

#### Display

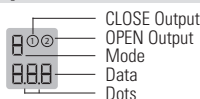

#### Active test input



= Symbol for display flashes

### 4 Standard operation

When everything is connected correctly:

Display after switching on: Status LED lights up green, Dots flash

Displays shown when safety edge is actuated: Status LED lights up orange



### 5 Diagnostic menu

Press the «Mode» and «Data» buttons simultaneously for 2 s → status LED flashes orange. Press «Mode» buttons briefly to change to the next mode. Press the «Mode» button for 2 s to exit diagnostic menu.

#### Error display mode

The 5 most recent errors can be interrogated. Press the «Data» key briefly in each case, and the errors are displayed one after the other. End appears when the «Data» button is pressed for the 5th time. The malfunctions are displayed in chronological order (new → old)

#### Mode «r» Resistance

The resistances of the safety edges are displayed. Example: 8 = Resistance between 7 and 9 kohm. 1 = safety edge ①. To access the next safety edge: Press the «Data» button

#### Mode «S» Output CLOSE

CLOSE Output: Press the «Data» button. The CLOSE Output is deactivated. Press the «Data» button again. The CLOSE Output is activated.

#### Mode «S» Output OPEN

OPEN Output: Press the «Data» button. The OPEN Output is deactivated. Press the «Data» button again. The OPEN Output is activated.

#### Mode «S» Simulation test

Both outputs: Press the «Data» button. Both outputs are deactivated. Press the «Data» button again. Both outputs are activated.

#### Mode «I» Test input

Display when test input inactive. Display when test input active.

#### Mode «C» current configuration

Displays current configuration of safety edge inputs, see configuration table. Configuration → chapter 6

#### Mode «c» current configuration test signal

Displays current configuration, test signal, see test pulse table. Configuration → chapter 6

#### Mode «e» current fall-delay time

Displays current fall-delay time, see fall-delay time table. To access the config. mode: Press the «Mode» button. Configuration → chapter 6

## 6 Configuration mode (for configuration before starting up, via diagnostic menu, after mode «h»)

 Please read chapters 6.1 to 6.4 in full before attempting configuration.

### 6.1 Activating configuration menu

 Status LED flashes orange, press «Data» button

 Press the «Mode» and «Data» buttons simultaneously for 2 s. Configuration menu is activated.

Configuration menu can be **exited** at any time by pressing the «Mode» button (2 s). «End» is displayed → Press «Data» button and release → Restart undertaken with new configuration.

### 6.2 Configuration of safety edge inputs

 The current setting for the safety edge inputs is displayed.

 Use the «Data» button to set the **configuration** you want for the safety edge inputs (according to Table 1).

 Error messages may occur when restarting after configuration if the inputs do not match the configuration.

Display	Mobile safety edge CLOSE ①	Mobile safety edge OPEN ②	Stationary safety edge CLOSE ③	Stationary safety edge OPEN ④
unc	not configured			
001*	X		X	X
002	X	X	X	X
003			X	X
004	X	X		
005	X			
006	X	X	X	
007	X	X		X
008	X		X	
009	X			X
010			X	
011				X

Table 1

\*) Factory setting

### 6.3 Configuration Test input

 Press the «Mode» button briefly. Use the «Data» button to set the required test signal (according to Table 2).





Display	Test pulse
001	
002*	

Table 2

\*) Factory setting

### 6.4 Configuration fall-delay time

 Press the «Mode» button briefly. Use the «Data» button to set the required fall-delay time (according to Table 3).

 Then briefly press the «Mode» button and End appears.

→ The system is configured.  
→ Press «Data» button to restart.

Display	Fall-delay time
001	none
002	100 ms
003*	200 ms
004	500 ms
005	1000 ms

Table 3

\*) Factory setting

## 7 Error displays

 If an error is detected then the outputs are deactivated and symbols ① & ② and an error code are displayed. The status LED lights up red.

Display	E001	E002	E003	E004	E005	E006	E101/ E102
<b>Error</b>	Safety edge (SE) malfunction ①	SE malfunction ①	SE malfunction ①	SE malfunction ①	Cable circuit malfunction	Mounting ≠config. mode	Undervoltage/ overvoltage
<b>Remedy</b>	Check safety edge ①	Check SE ②	Check SE ③	Check SE ④	Check cable circuit < 3 ohm	Check configuration	Check supply

Should other fault messages appear, please contact your supplier.

## 8 Most important technical data

Operating voltage	InTra6 2	24 V AC/DC ± 15%,	Outputs	Semiconductor relay, 24 V AC/DC, max. 50 mA
	InTra6 2.LVAC	100-240 V AC 50/60 Hz		Test input
Power consumption	max. 3 VA		Dimensions (W x H x D)	Switching device ⑧ 22,5x94x88 mm
Safety edges	8,2 kOhm			Coil ⑦: 50x25x22 mm
				Converter ⑤⑥: 40x25x22 mm

## 9 Mounting

### 9.1 Electrical installation

1. Check that electrical components are all present by referring to component list 9.3.
2. Mount switching device in designated position.
3. Mounting of mechanical parts (see chapters 9.2 and 9.3).
4. Connect electrical lines as shown in terminal diagram in chapter 2.

### 9.2 Mechanical mounting

1. Check that mechanical components are all present by referring to component list 9.3
2. Mount the two mounting brackets ⑩ and the coil ⑦.
3. Pull in the steel cable (see chapter 9.4 and 9.5). Mount converter INTR-MOB ⑤ or ⑥.
4. Tension the steel cable ⑨ cable and fix it via the retaining screw ⑱. **The steel cable ⑨ must be able to move unimpeded through the INTR-FIX60 coil ⑦ along the full length of the gate.**
5. Connect steel cable ⑨ as described in chapter 9.5. Make sure the connection with the gate offers low resistance (clean the contact points and remove any paint).
6. Establish the electrical connection as shown in the terminal diagram in chapter 2.

### 9.3 List of electrical components

Components	Image	Qty	No.	Function
INTR-MOB61 (grey)		1	⑤	Converter, mobile sensor unit, transmits sensor status of primary closing edge
INTR-MOB62 (red)		evt. 1	⑥	Converter, mobile sensor unit, transmits sensor status of mobile secondary closing edge
INTRA6 2 switching device		1	⑧	Evaluation and switching device
INTR-FIX		1	⑦	Coil, transmits energy and information
Steel cable		1	⑨	Steel cable, forms the low-resistance cable circuit together with the gate structure (< 3 ohm!)

INTR-ASK60 components				
Mounting bracket		2	⑩	For fastening the cable to the gate
Banjo bolt, smooth, 8x60 with steel cable fixing screw (M4x10)		1	⑪	Part of cable tensioning device
Banjo bolt		1	⑫	Part of cable tensioning device
Cable lug 2.5 mm <sup>2</sup>		2	⑬	For connecting steel cable to gate
Compression spring		1	⑭	Part of cable tensioning device
Hexagon bolt M6x12 including washer		6	⑮	For fastening bracket / cable to gate
Hexagon nut M6		2	⑯	Part of cable tensioning device (on banjo bolt)
Plastic sleeve		2	⑰	For insulation between banjo bolt / hollow pin and mounting bracket
U-shaped washer for M8		2	⑱	Part of cable tensioning device (on banjo bolt)
Screw M4 x 10		2	⑲	For fixing the cable in the banjo bolt / hollow pin

### 9.4 Arrangement on a gate (example)

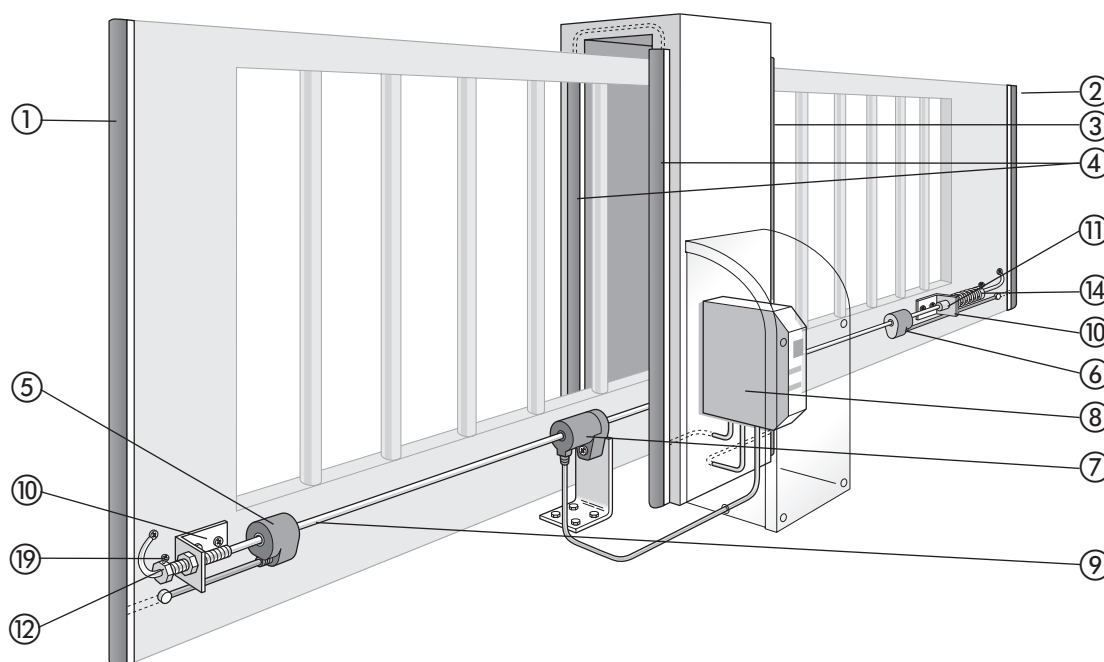

## 9.5 Mounting steel cable

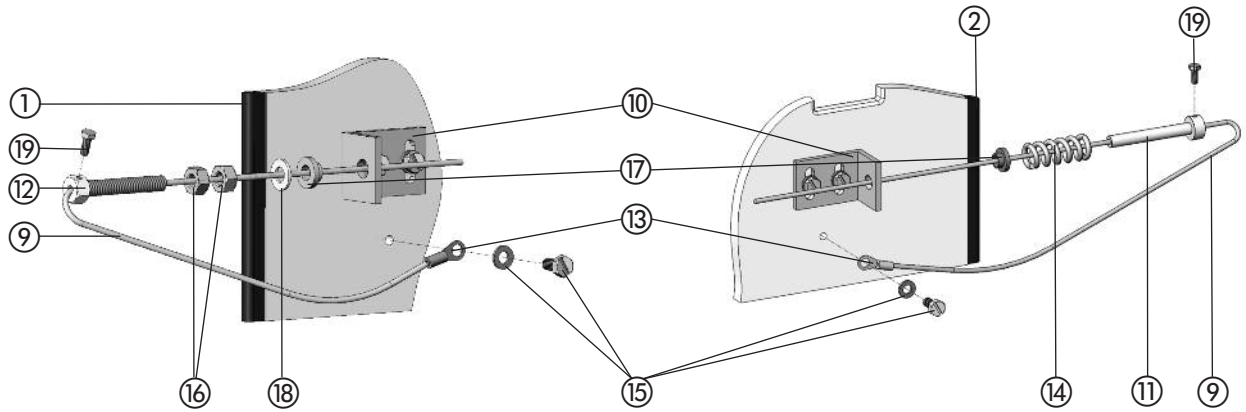

## 9.6 Mounting substructure

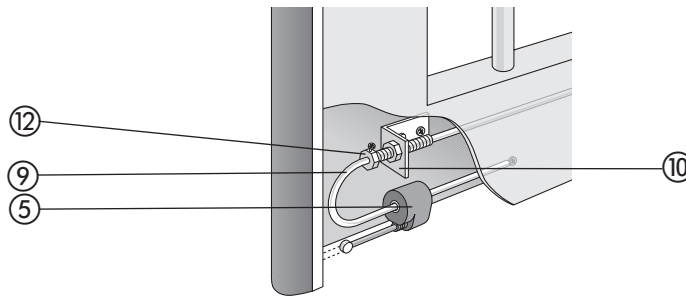

## 10 EC Declaration of conformity, date of production

### 10.1 EC Declaration of conformity

Manufacturer:	Bircher Reglomat AG, Wiesengasse 20, CH-8222 Beringen
Employee responsible for documentation:	Bircher Reglomat GmbH, Dr. Marc Loschonsky, Robert-Bosch-Strasse 3, DE-71088 Holzgerlingen
Product:	Inductive signal transmission system, safety switching device
Models:	InTra6 2, InTra6 3
Notified Body:	Suva, Bereich Technik, SCESp 008, Kenn-Nr. 1246
Type-examination certificate:	E 6934, E 6935
Fulfills the essential requirements in acc. with:	2006/42/EG, 1999/5/EG
Following standards were applied:	EN ISO 13849-1:2008+AC:2009
Signee:	CTO Dr. Marc Loschonsky, COO Daniel Nef

### 10.2 Date of production

See shield → week/year, e.g. 12/10 = week 12, 2010

## 11 Contact data

**Authorised representative:**  
**Bircher Reglomat GmbH**  
**Robert-Bosch-Strasse 3**  
**D-71088 Holzgerlingen**  
**Germany**  
**www.bircher-reglomat.com**

**Manufacturer:**  
**Bircher Reglomat AG**  
**Wiesengasse 20**  
**CH-8222 Beringen**  
**Switzerland**  
**www.bircher-reglomat.com**

**Seller**  
**Swissdoor ApS**  
**Stenhuggervej 2**  
**DK-5471 Søndersø**  
**Tel.: +45 86 28 00 00**  
**mail@swissdoor.dk**  
**www.swissdoor.dk**