

CleanSwitch

Touchless switch

Original instructions

General

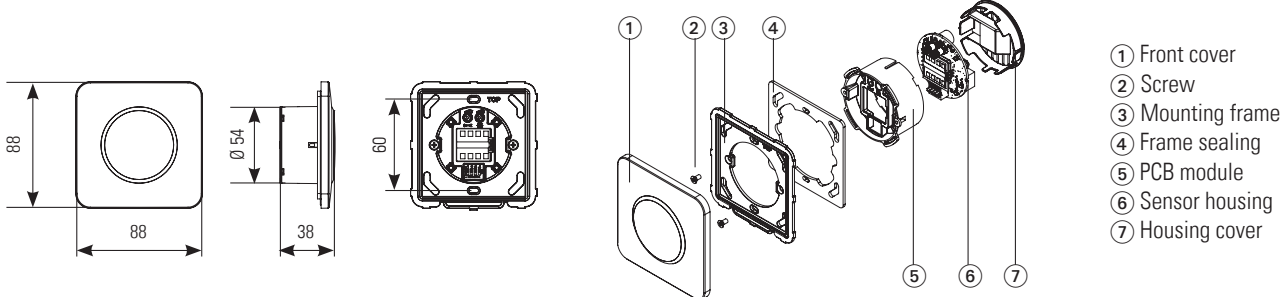

1 Safety instructions

The unit may only be installed and commissioned by trained and qualified personnel.

The unit may only be opened and repaired by the manufacturer.



This unit may only be operated from a protective low-voltage with safe electrical isolation.

Always consider the safety functions of your application as a whole, never just in relation to one individual component of the system.

The installer is responsible for carrying out a risk assessment and installing the detector and the system correctly.

Avoid touching any electronic components.

2 Assembly

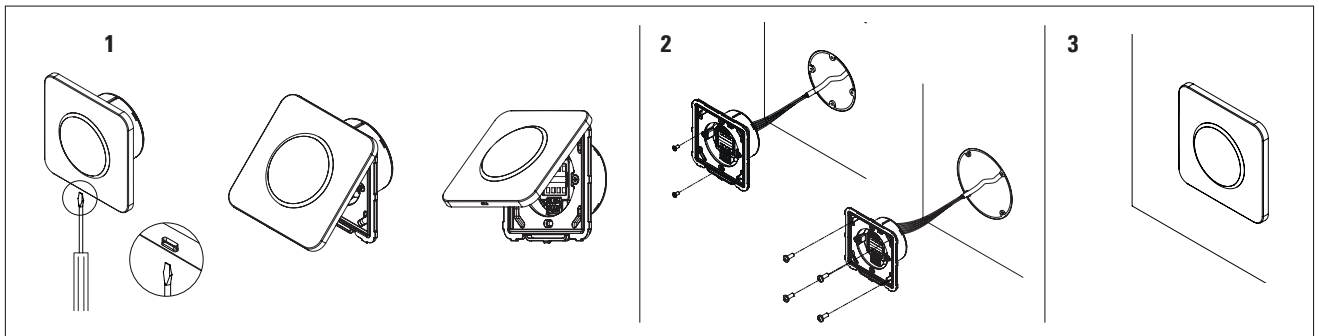

3 Configuration

Factory settings

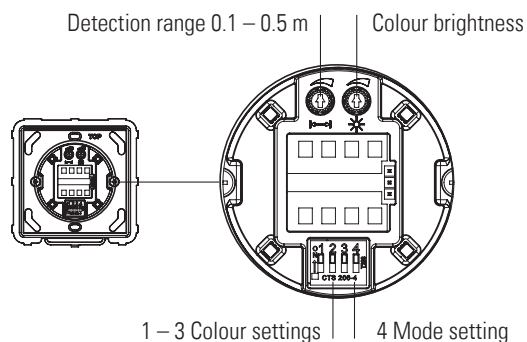

DIP switches

1 – 3 Optical feedback

ON	1	2	3	4	Green / Red	ON	1	2	3	4	Red / Red
ON	1	2	3	4	Red / Green	ON	1	2	3	4	Blue / Blue
ON	1	2	3	4	Blue / Green	ON	1	2	3	4	- / Green
ON	1	2	3	4	Green / Green	ON	1	2	3	4	- / Blue

4 ON Toggle Mode

4 OFF Pulse Mode

ON	1	2	3	4	ON Toggle Mode
ON	1	2	3	4	OFF Pulse Mode

4 Electrical connections

Supply -	White	1
Supply +	Red	2
Relay COM	Green	3
Relay NC	Grey	4
Relay NO	Blue	5

Stripping length min. 8.5 mm (solid or flexible wire)

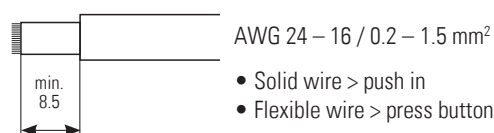

6 Technical data

Technology	Microwave Doppler Radar
Frequency	24.125 GHz
Detection range	0.1 – 0.5 m
Detection mode	Pulse mode: sensor detects while hand is moving Toggle mode: first movement on/ second movement off
Detection speed	Min: 5 Hz or ± 3 cm/s Max: 200 Hz or ± 1.2 m/s
Supply voltage	12 – 24 VAC ± 10 % (50 – 60 Hz) 12 – 24 VDC + 20 % / – 10 %
Max. power consumption	< 1 W (with optical feedback)
Output	Relay with switch-over contact (free of potential) Max. switching voltage/current (DC): 1A up to 30V, 0.5A up to 60V Max. switching voltage/current (AC): 1A up to 60V, 0.5A up to 125V Max. switching power: 30 W (DC) / 60 VA (AC)
Output hold time	"Relay hold time": 0.3 s "LED hold time": 2 s
Storage / operation temperature	– 20 to + 60 °C
Protection class	IP65 (fixed with 4 screws, smooth surface)
Dimension (mm)	88 x 88 x 38 mm (L x W x H)
Weight	55 g
Materials	ASA / PC

Note: CleanSwitch is according VAH list resistant to surface disinfectants in hospitals.

7 Declaration of conformity, identification of the year of manufacture by means of the serial number

7.1 EC-Declaration of Conformity

Manufacturer: Bircher Reglomat AG, Wiesengasse 20, CH-8222 Beringen
Following directives have been observed: RoHS 2011/65/EU, RED 2014/53/EU
Product variant: CleanSwitch

7.2 FCC approval

This device meets the requirements of Part 15 of the FCC regulations and the RSS-210 standard of Industry Canada.



Warning: Changes or modifications made to this equipment not expressly approved by Bircher Reglomat AG may void the FCC authorisation to operate this equipment.

7.3 Identification of the year of manufacture

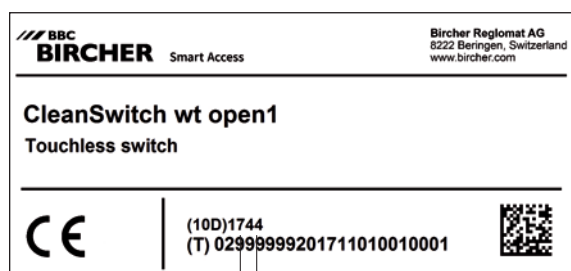

Year | Week
17 | 44

8 Contact

Manufacturer

BBC Bircher Smart Access
Bircher Reglomat AG
Wiesengasse 20
CH-8222 Beringen
www.bircher.com

Seller

Swissdoor ApS
Stenhuggervej 2
DK-5471 Søndersø
Telefon +45 86 28 00 00
mail@swissdoor.dk
www.swissdoor.dk